



# Contents

## CONTENTS

1. Specifications .....	2
2. Outline and Dimensions .....	3
3. Operation .....	5
4. Wiring Diagram .....	18
5. Refrigerant Cycle .....	20
6. Control Block Diagram .....	21
7. Electric Circuit Diagram .....	22
8. Trouble Shooting .....	25
9. Disassembly Instructions .....	41
1) Indoor Unit .....	41
2) Outdoor Unit .....	43
3) Exploded Diagram (Indoor Unit) .....	44
4) Exploded Diagram (Outdoor Unit) .....	47
5) Control Box Assembly .....	50

# 1. SPECIFICATIONS

## ◆DSB-181LH

ITEM		MODEL	DSB-181LH	
Function			COOLING	HEATING
Class			T	
Power			220~240V/ 50Hz	
Capacity	W		5,110	5,400
	Btu/h		17,500	18,500
Dehumidification		l/h	2.2	
Electrical Data	Running Current	A	10.8	11.5
	Power Input	W	2,050	2,230
	Starting Current	A		
Compressor	Type		Rotary	
	Model		2JS350D6BA02	
	Capacitor		35 $\mu$ F/370V AC	
Fan			Indoor Unit	Outdoor Unit
	Type		Cross flow fan	Propeller fan
	Capacitor		1.2 $\mu$ F/450V AC	3 $\mu$ F/370V AC
	Motor Model Number		IC-9425 DWKC 5A	AM 12DPD04
Refrigerant (R-22)	Control		Capillary	
	Charge Q'ty	g	1320	
Connection	Type		Flare	
	OD (Liquid/Suction)	in(mm)	1/4 (6.35)	1/2 (12.7)
Dimensions (W x H x D)		mm	1,035 x 322 x 205	800 x 615 x 277
Net Weight		kg	12.1	51.9

# 2. OUTLINE AND DIMENSIONS

## 1 INDOOR UNIT

◆DSB-181LH

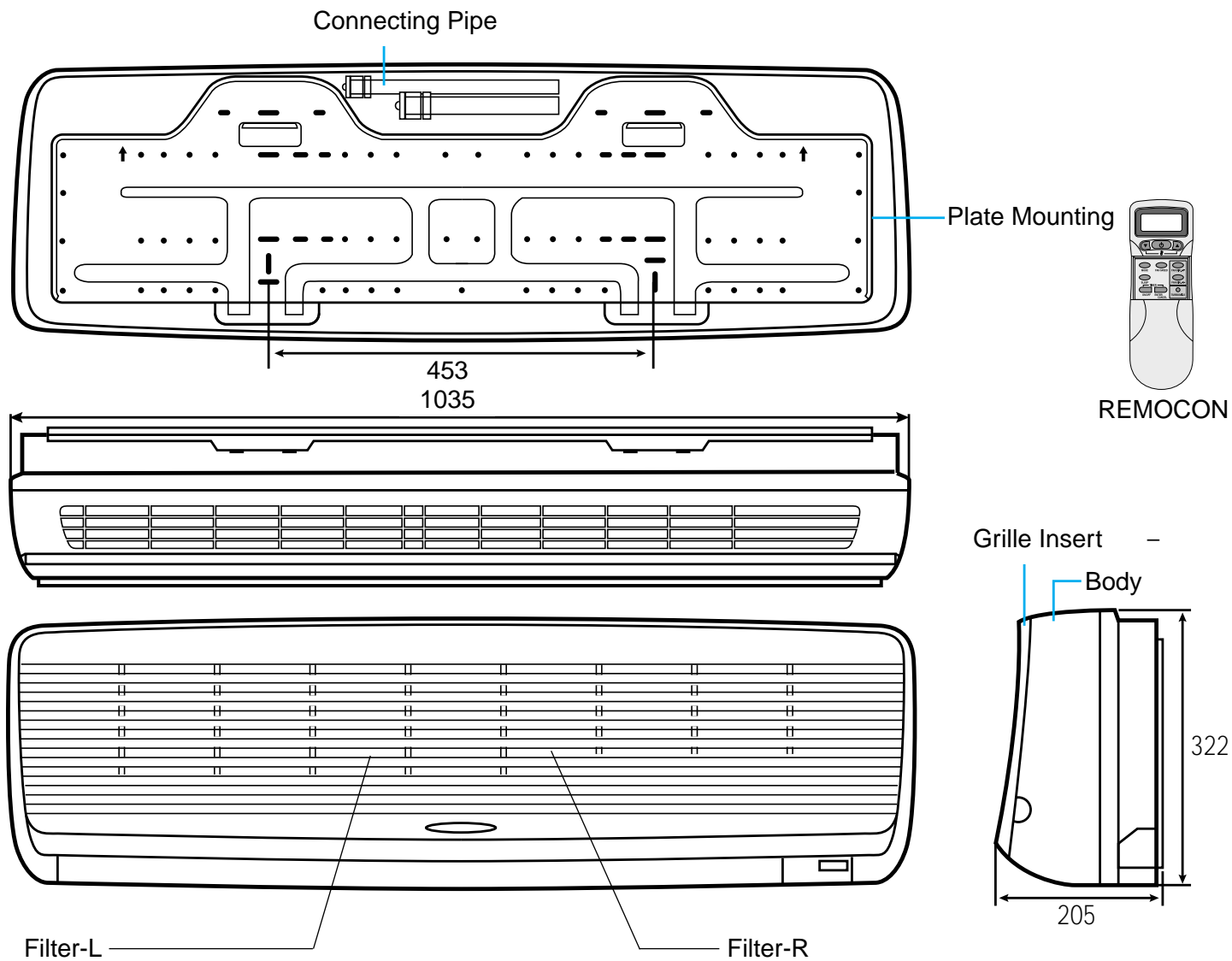

## 2 OUTDOOR UNIT

◆DSB-181LH

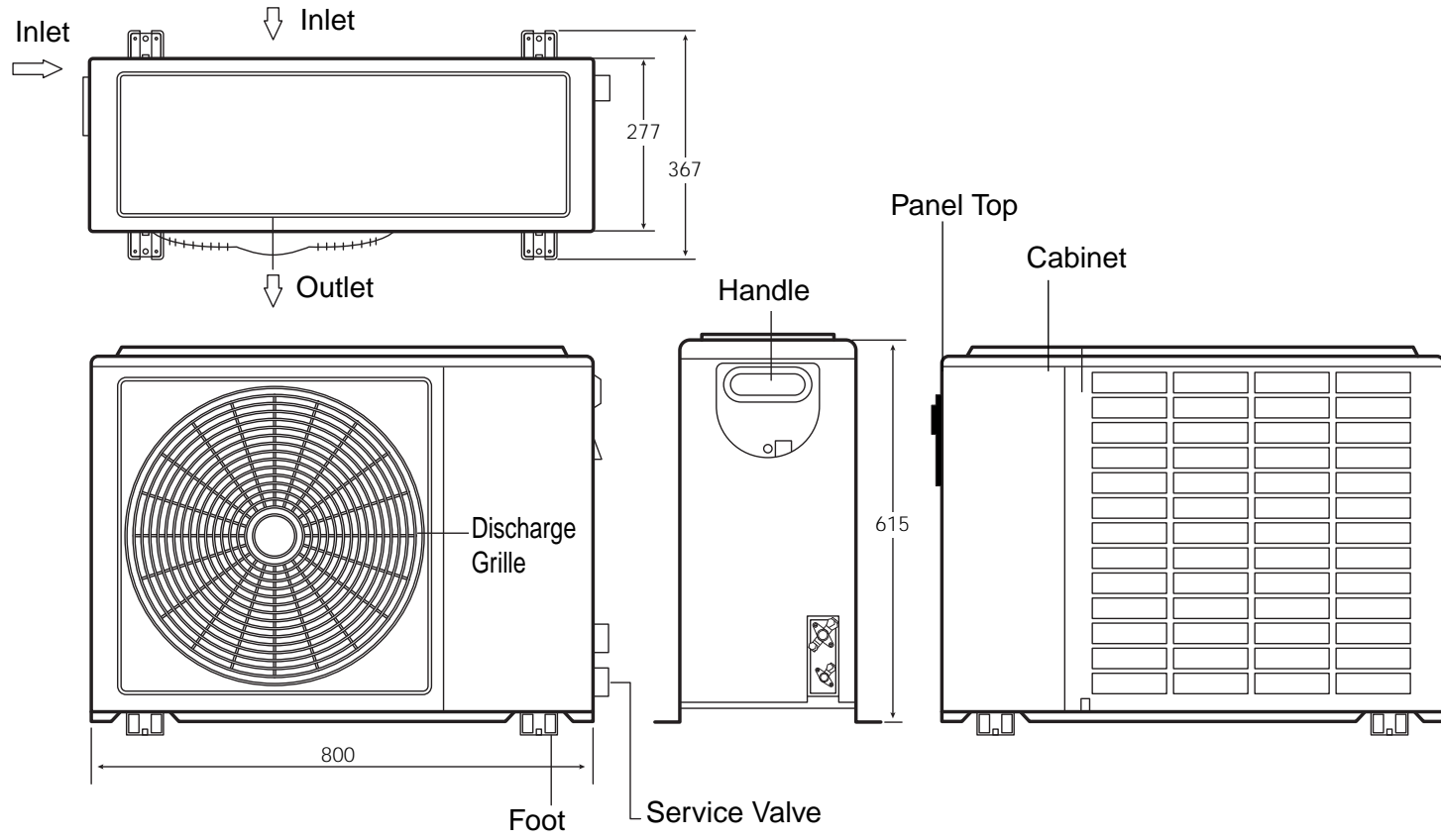

# 3. OPERATION

## 1 PARTS OF NAME AND FUNCTION

◆DSB-181LH

### Indoor Unit

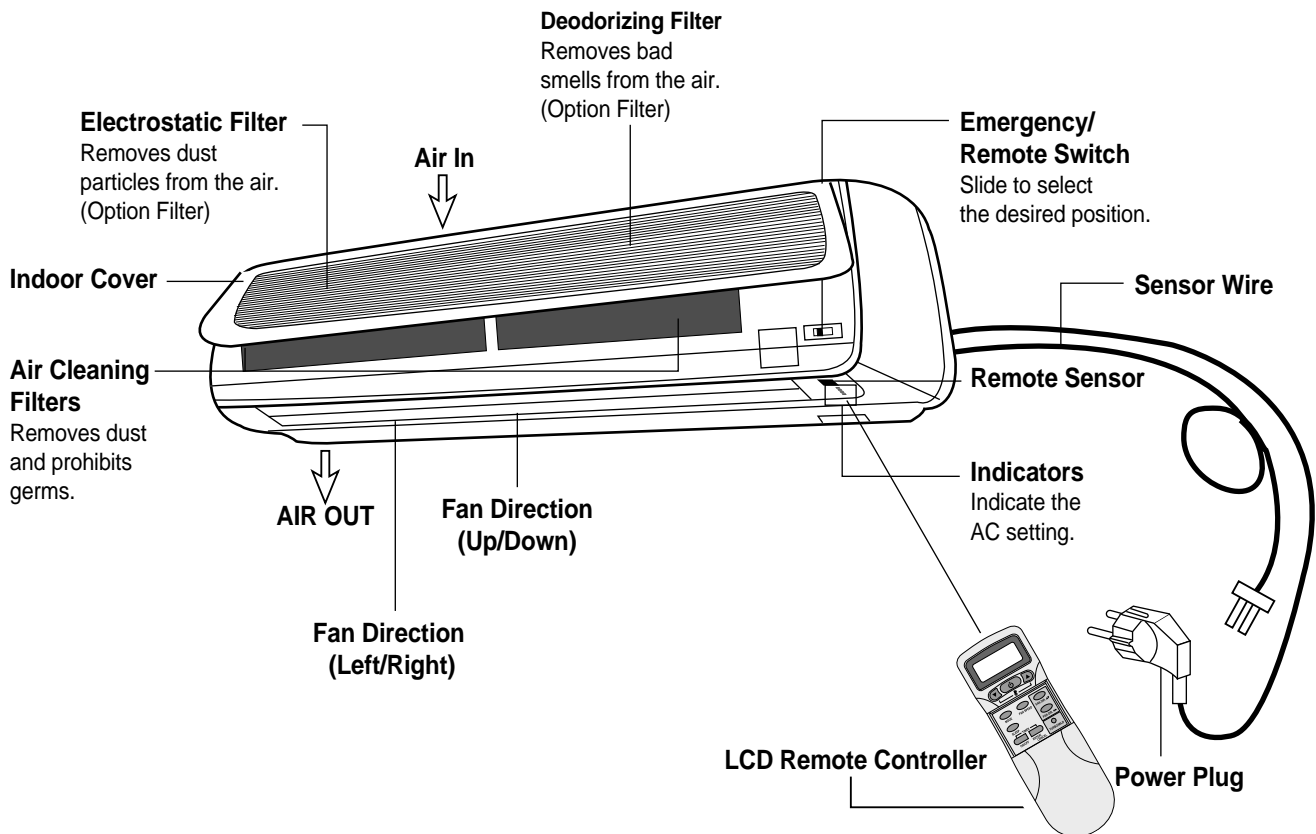

●DSB-181LH

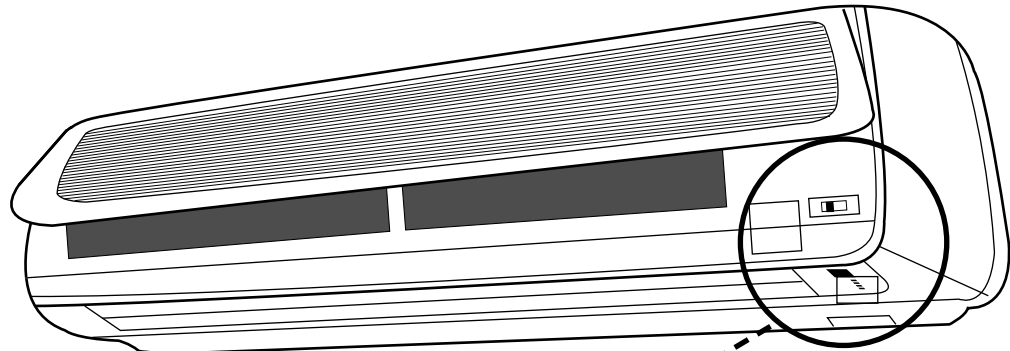

**Indoor Unit Display**

■ Remote Control Signal Receiver

This place is the part to receive the signal if it receive the signal, you can hear the signal “beep. beep”.

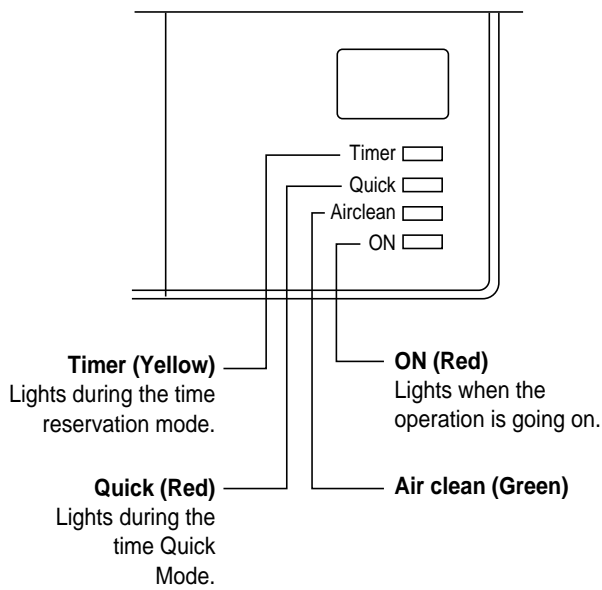

**Switch Panel**

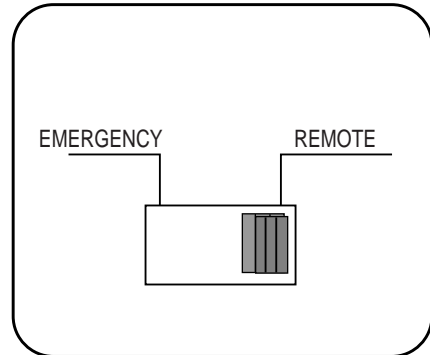

■ There is a switch panel at inside of Front Panel.

At the time of operating, open the Front Panel.

Emergency switch can be used when the remote controller is lost or Testing.

Remote switch is usually used by remote controller.

● DSB-181LH

**Outdoor Unit**

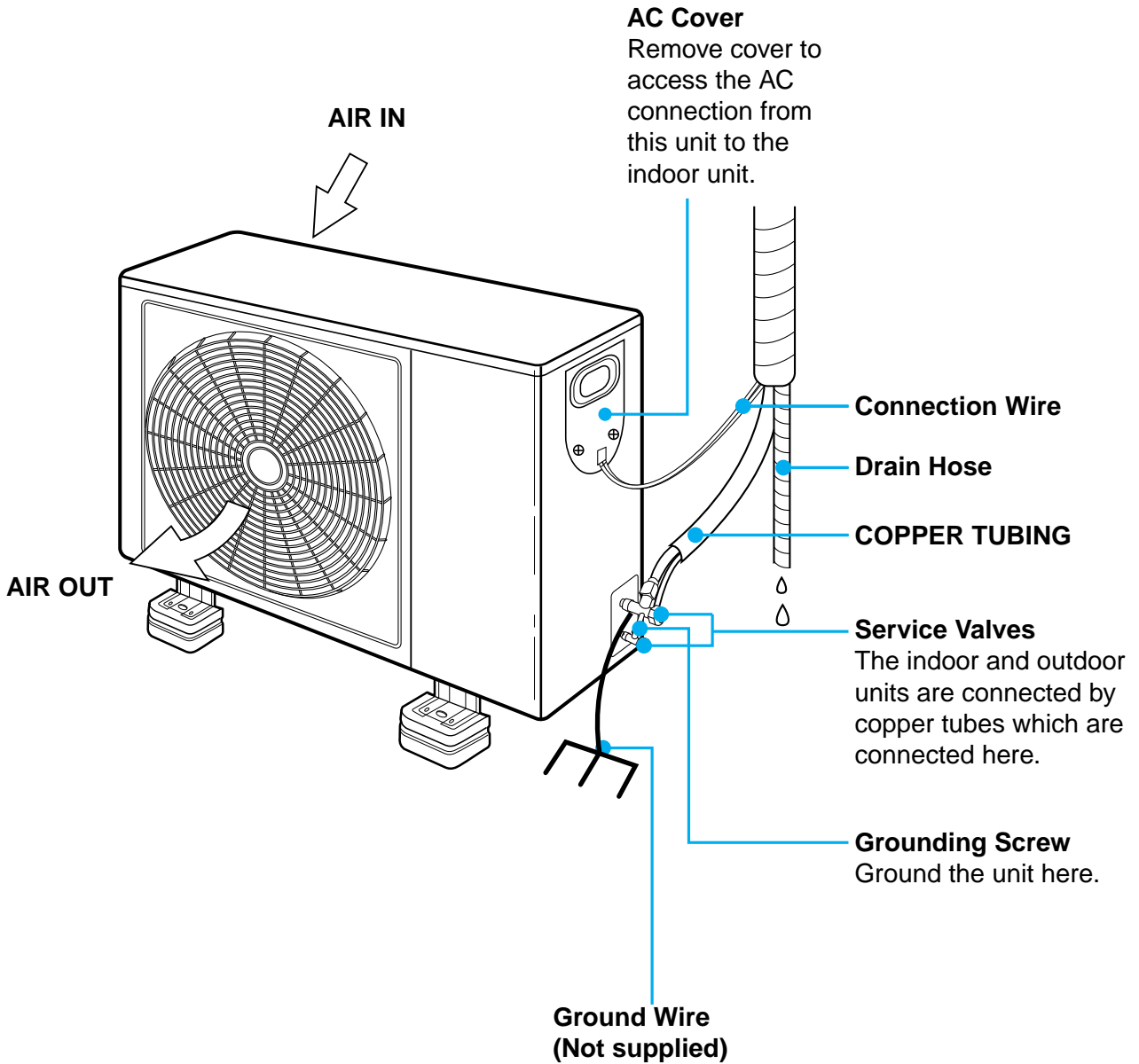

## 2 REMOTE CONTROLLER

●DSB-181LH

### Name of Each Button

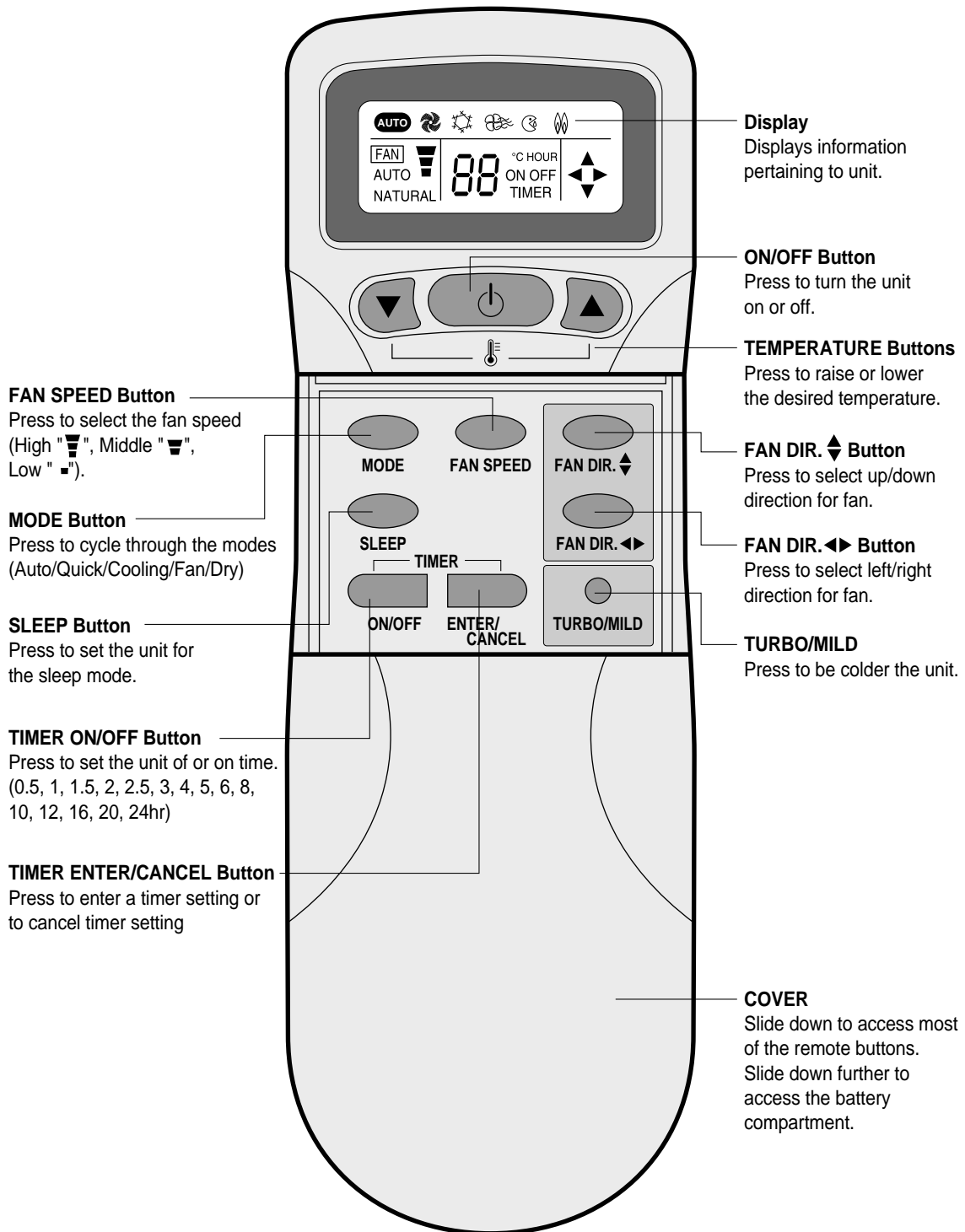

# 3 REMOTE CONTROLLER DISPLAY

## ● DSB-181LH

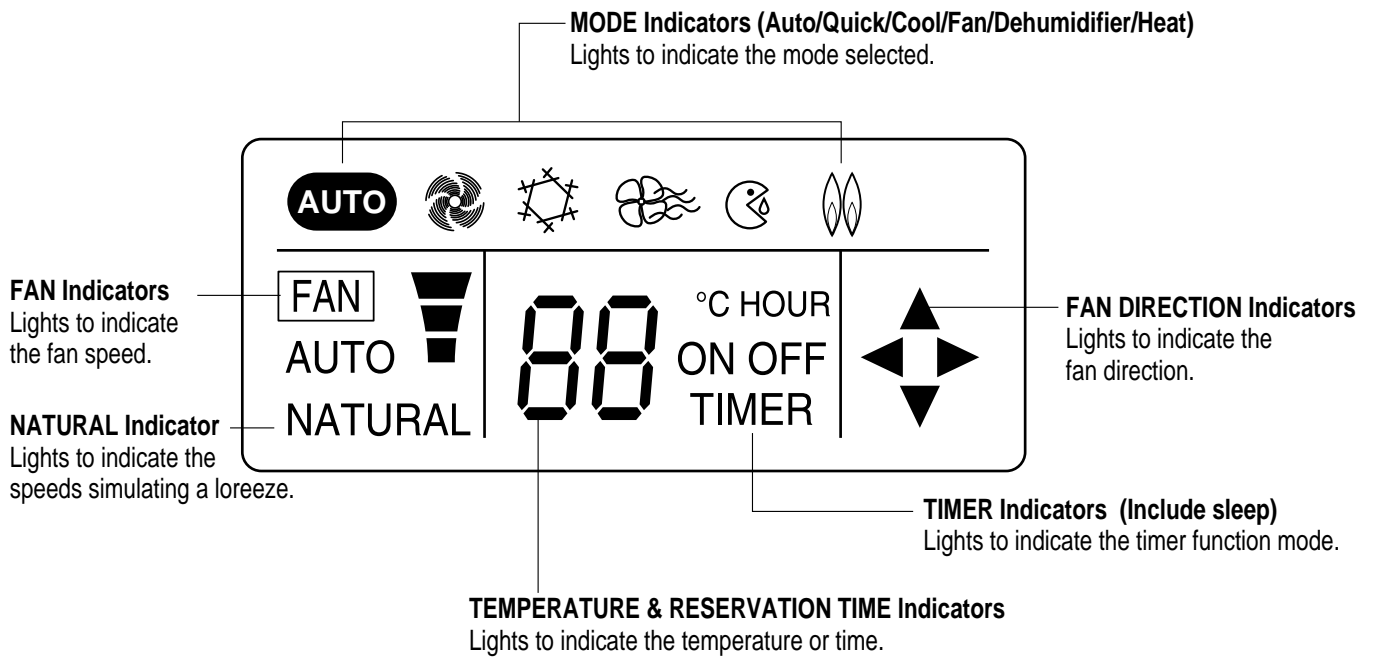

## Replacing Batteries

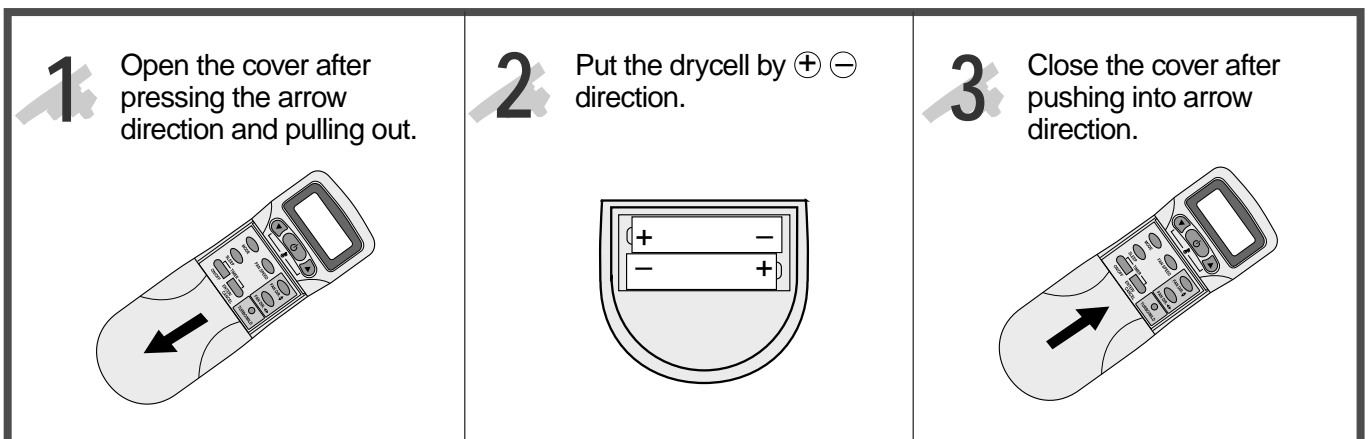

## 4 DESCRIPTION OF FUNCTIONS

### OFF-Timer

If you set time in OFF-Timer Mode, the unit will stop at the set time.

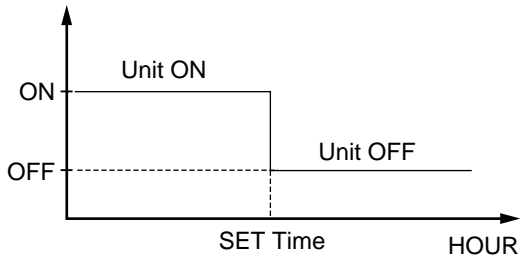

### ON-Timer

If you set time in ON-Timer Mode, the unit will run at the set time.

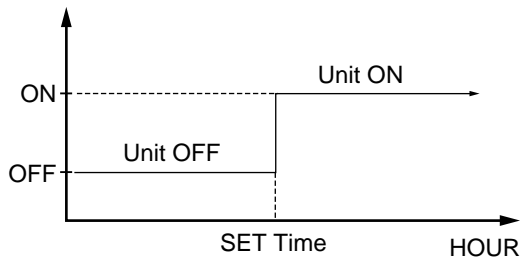

### Control of Room Temperature

- (1) Range of setting temperature: 18~32°C
- (2) Setting temperature: Operating temperature of compressor

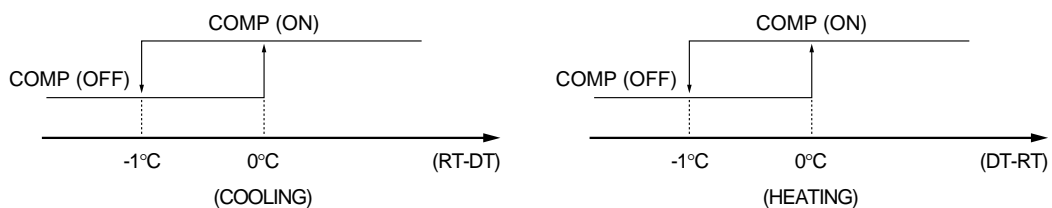

\*RT: ROOM TEMPERATURE  
DT: DESIRED TEMPERATURE

- (3) During the time of test operating, Fan (Indoor, Outdoor) and Compressor is running regardless of room temperature.

### Buzzer

If the Indoor Unit Display receive the signal of Remote Controller, you can hear the signal "beep –" or "beep, beep".

## Fan Speed (Indoor Unit)

- (1) Motor speed (high speed, normal speed, low speed).
- (2) Remote controller setting fan speed. (Auto, L, M, H, Natural)
- (3) Relation of operating mode between fan speed. (legned: X-no relation)

	FAN ONLY	COOL	DEHUMI-DIFICATION	AUTO	QUICK	HEAT
H	H	H	X	H	X	H
M	M	M	X	M	X	M
L	L	L	X	L	X	L
Auto	X	Auto	Auto	Auto	X	Auto
Natural	Natural	Natural	X	Natural	X	Natural

### (4) Automatic Operation

If the unit is set in 'AUTO' mode, the unit operates automatically according to the room temperature to keep the room temperature comfortable.

(COOLING)

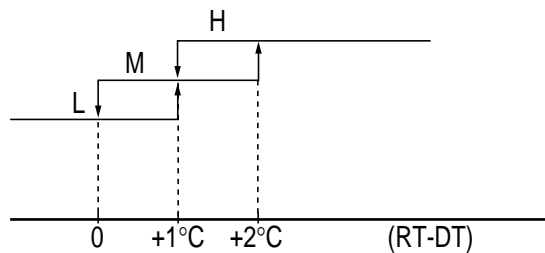

(HEATING)

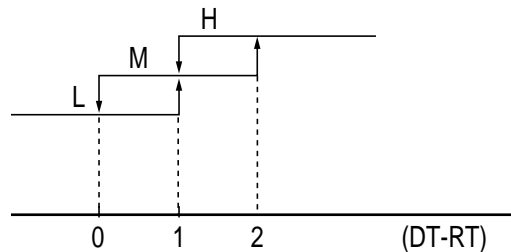

## Sleep Mode

- (1) When you are going to sleep, select sleep switch and the unit controls the room to the desired temperature.  
(The unit will not operate after 4 hour)
- (2) For changing the temperature.

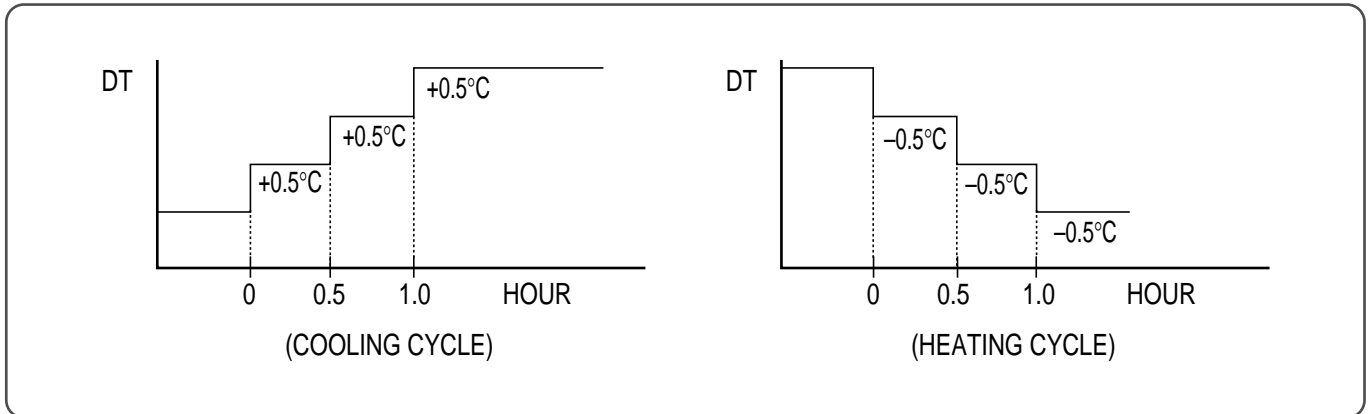

- (3) To cancel sleep mode, press the SLEEP button again or press the MODE button once.: the SLEEP indicator will disappear in the display.

## Emergency Operation

- (1) When the remote controller is lost, damaged or the battery is discharged, the Emergency operation can be used to run the unit.
- (2) The setting conditions of Emergency operation are as follows.
  - Operation mode: AUTO
  - Preset temperature:  $26^{\circ}\text{C}$
  - Discharge Air Direction: SWING (up and down Left and Right)
  - Fan speed: AUTO

## Frost Prevention of Indoor Unit

When the unit operates at low ambient temperature, frost may appear on the Evaporator. When the indoor coil temperature is lower than 0°C at the end of 10 minutes of continuous compressor operation from the start, the microcomputer of the unit stops the compressor to protect the unit from the frost. The control procedure for indoor coil freeze protection.

- 1) The compressor and outdoor fan turn off.
- 2) Indoor fan operates according to user set speed.
- 3) The normal operation returns when the indoor coil temperature is higher than 7°C or equal to 7°C.

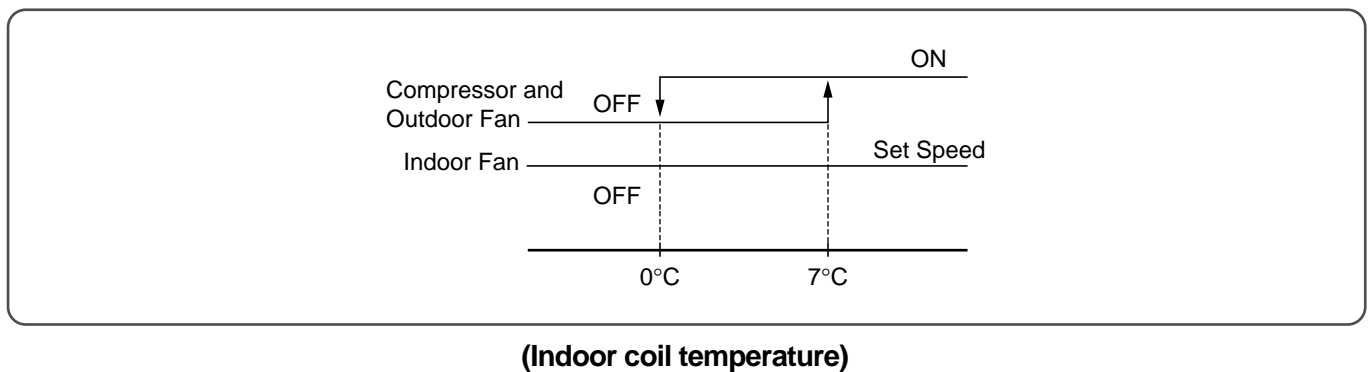

## 3 min. Time Delay of Compressor

In normal operation, there is a time delay of three minutes between turn off and turning back on including initial power up.

## Indoor Fan Motor Starting

When indoor fan motor is on, it always starts at normal speed and then it operates desired speed.

## 5 Seconds Time Delay of Indoor Fan Motor

When the speed of indoor fan motor changes, there is a time delay of 5 seconds at each speed step.

## Auto Mode

### (1) In Auto Mode

After the indoor fan is operated for 20 seconds in the Auto Mode, the unit will operate automatically by selecting operating Mode according to the room temperature

(RT: Room temperature)

ROOM TEMPERATURE	OPERATING MODE	FLAP POSITION
$28^{\circ}\text{C} \leq \text{RT}$	Cooling	Cooling Position
$22^{\circ}\text{C} < \text{RT} < 28^{\circ}\text{C}$	Dehumidifier	Cooling Position
$\text{RT} \leq 22^{\circ}\text{C}$	Heating	Heating Position

### (2) Selecting Operating Mode Again

Room temperature meets desired temperature and the compressor stops running over 30 minutes, then the unit selects operating Mode again.

## Dehumidification Mode

- !Desired temperature < Room temperature  
Outdoor Fan, Compressor : ON  
Indoor Fan : Low speed
- @ Desired temperature  $\geq$  Room temperature  
Compressor : 3 min/ON, 5 min/OFF  
Indoor Fan : 3 min 30 second/ON, 4 min 30 second/OFF  
Fan Speed : Ultra low speed
- # Room temperature  $\leq$  18°C  
Compressor : OFF  
Indoor Fan : 1 min/ON, 7 min/OFF  
Fan speed : Ultra low speed

## Air Discharge Direction

- (1) When you turn on the unit, the flaps move to the position of keeping the room temperature comfortable.
- (2) The air discharge direction procedure is below.

UP/DOWN  $\longrightarrow$  ON/OFF  
LEFT/RIGHT  $\longrightarrow$  ON/OFF

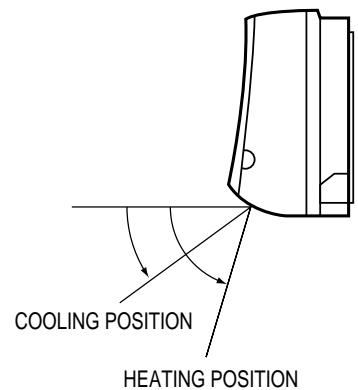

## Auto Mode II(Powerful Cooling)

- (1) Cooling Condition (Room Temperature > 22°C)  
!Fan Speed: Super high speed
- @ Air discharge direction: Fixed
- # Set temperature: 18°C (Fixed)
- \$ Operation Mode: Cooling Mode
- % Compressor and Outdoor Fan

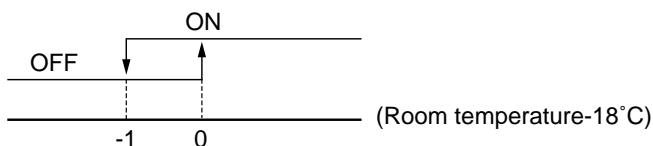

(2) Heating Condition (Room Temperature  $\leq 22^{\circ}\text{C}$ )

!Fan Speed: Super high speed

@ Air discharge direction: Fixed

# Set temperature:  $32^{\circ}\text{C}$  (Fixed)

\\$ Operation Mode: Heating Mode

% Compressor and Outdoor Fan

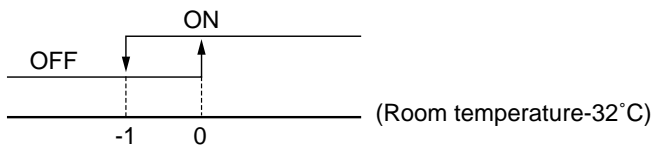

## Cooling Airflow Prevention

When the indoor coil temperature is lower than  $30^{\circ}\text{C}$ , Microcomputer of the unit stops indoor fan to prevent cooling airflow.

## Heating Airflow Prevention

When the indoor coil temperature is higher than  $65^{\circ}\text{C}$ , Microcomputer of the unit stops the compressor to prevent it from overheating. In the function of HEATING AIRFLOW PREVENTION, when pressing FAN SPEED button, Remote controller received the signal, but the unit don't operate.

After resetting the function of HEATING AIRFLOW PREVENTION, the unit operate by receiving the signal.

## Defrost Airflow Prevention

In HEAT mode, the defrost is performed in the following conditions

-When the outdoor coil temperature is less than or equal to  $-5^{\circ}\text{C}$

-The compressor run time is greater than 50 minutes.

# Self-Diagnostic Function

The control will contain diagnostic test to verify the integrity of the system.

(1) Error Code Display Pattern

! ON LAMP: ON (Red) LED ON/OFF

@ Error Code (Display in Emergency Mode only)

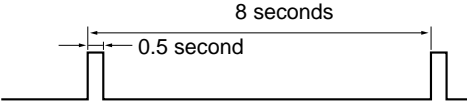
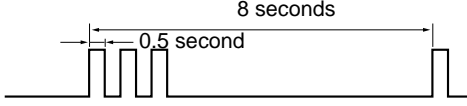
ERROR CODE	DISPLAY PATTERN	ERROR CONTENTS
1		Room air thermistor, connector Indoor coil thermistor, connector
2		Compressor, Electrical parts of comp. Gas leak

# 4. WIRING DIAGRAM

◆ DSB-181LH

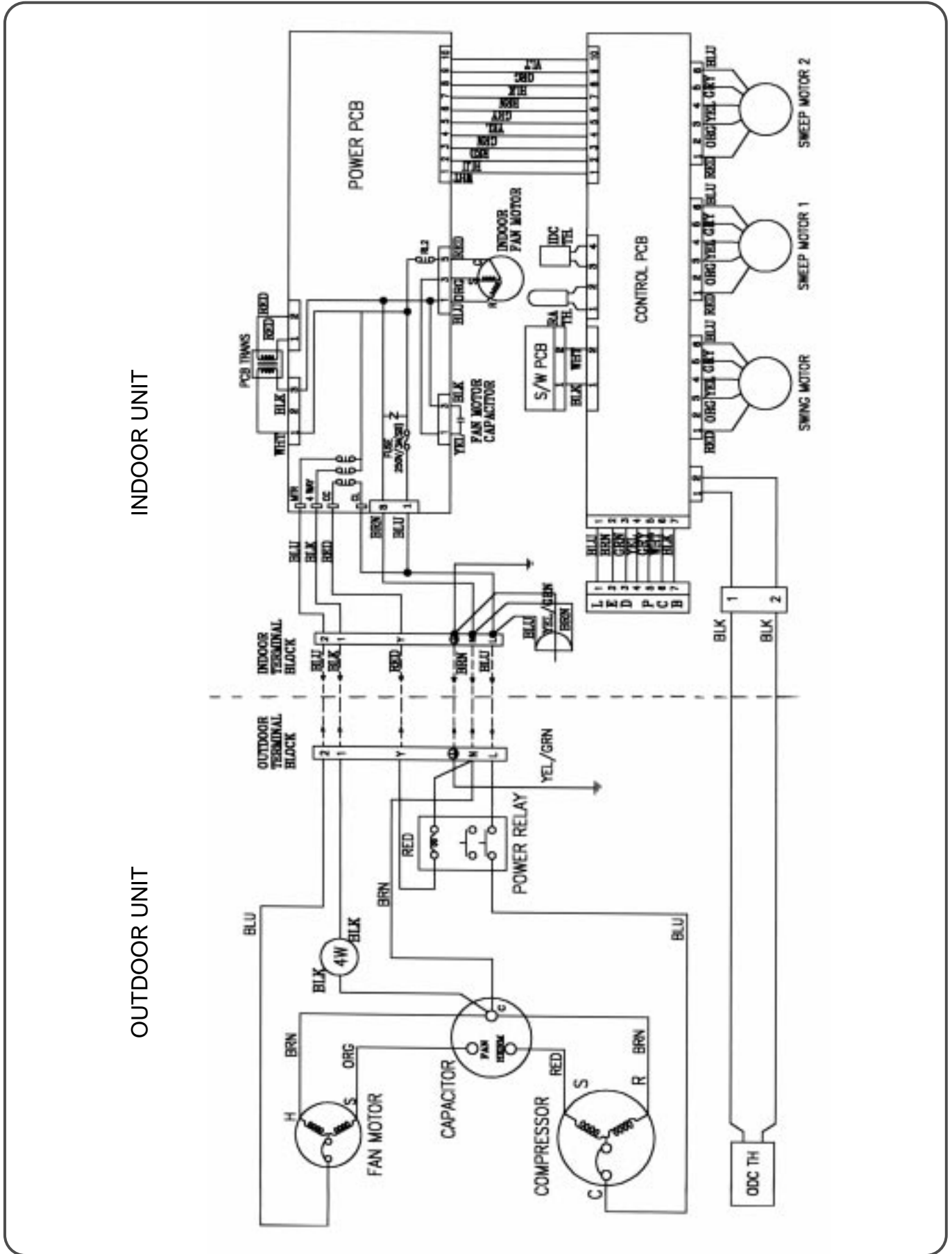

# 1 MAIN ELECTRIC PARTS

## ◆ DSB-181LH

	PART NAME	PART CODE	SPEC.	QUANTITY	REMARK
<b>Indoor Unit</b>	Fan Motor	3108000311	IC-9425 DWKC 5A	1	
	Fan Motor Capacitor	3106995010	1.2 $\mu$ F 450VAC 0.2A	1	
	Fuse	5FVLB3152L	250V/50T 3.15A	1	
	Transformer	3100007610	DWA-220V/50Hz	1	
	Stepping Motor 1	3108004310	MP28GA (L=1300mm)	1	
	Stepping Motor 2	3108004300	MP28GA (L=400mm)	2	
	Terminal Block	3108912330	SN-DBW-6P	1	
<b>Outdoor Unit</b>	Compressor	3107130000	2JS350D6BA02	1	
	Duol Capacitor	3109500200	370V 35/3 $\mu$ F	1	
	Fan Motor	3108000400	AM12DPD04	1	
	Power Relay	5SC0202700	G7L-2A-TUB	1	
	Terminal Block	3108912330	DBW-6P	1	
	Reversing Valve	3105400300	V2-100	1	
	Solenoid Coil	3109700100	L30-0240	1	

# 5. REFRIGERANT CYCLE

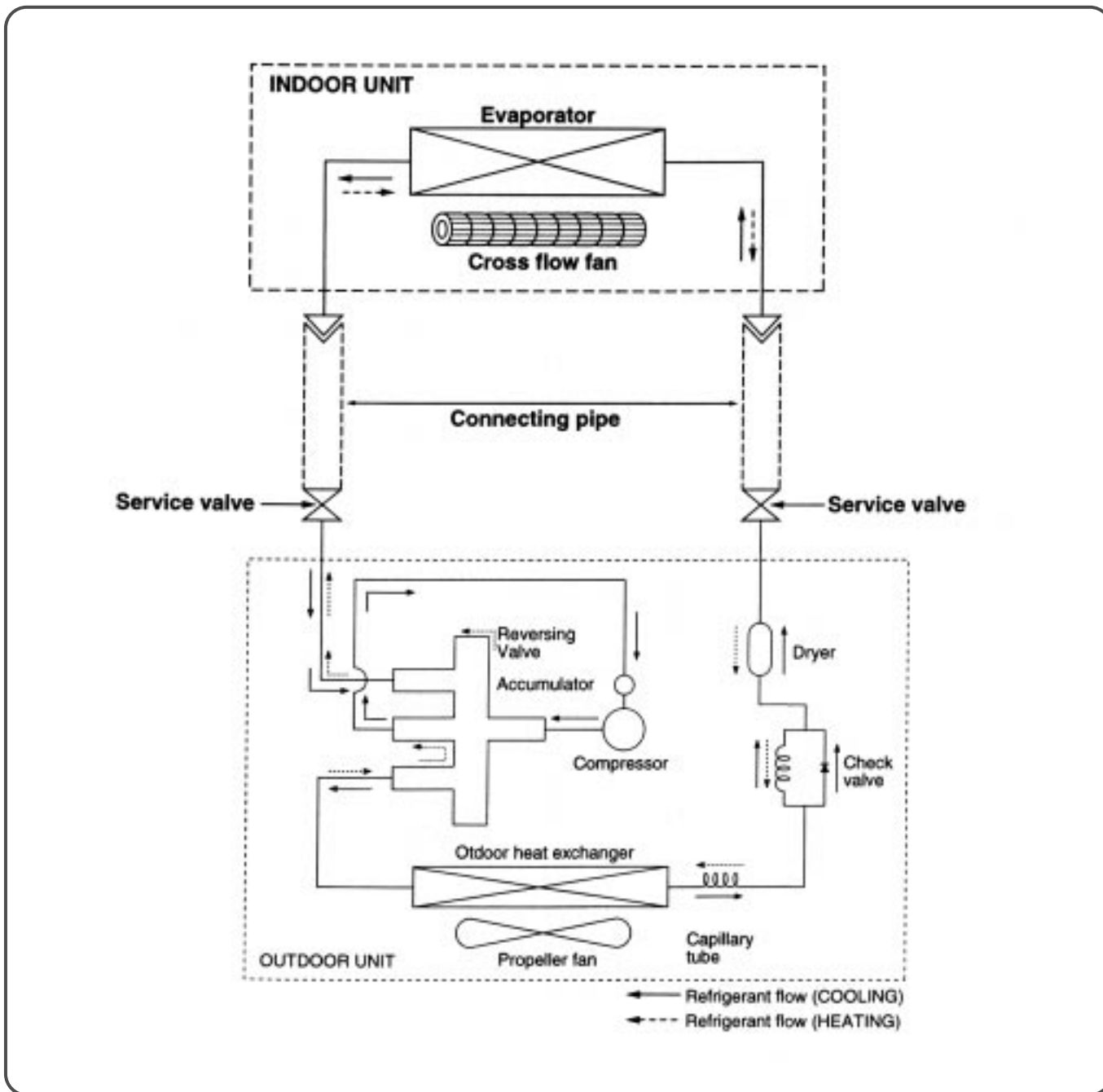

**Note)** If the pipe length exceeds the standard length, add 30g of refrigerant per extra meter.

Model Name	DSB-181LH	
Contents		
Capillary tube	ID2.0Ø x OD3.0Ø x L700	ID1.78Ø x OD3.0Ø x L800
Charge Quantity	1320g	

# 6. CONTROL BLOCK DIAGRAM

## ◆ DSB-181LH

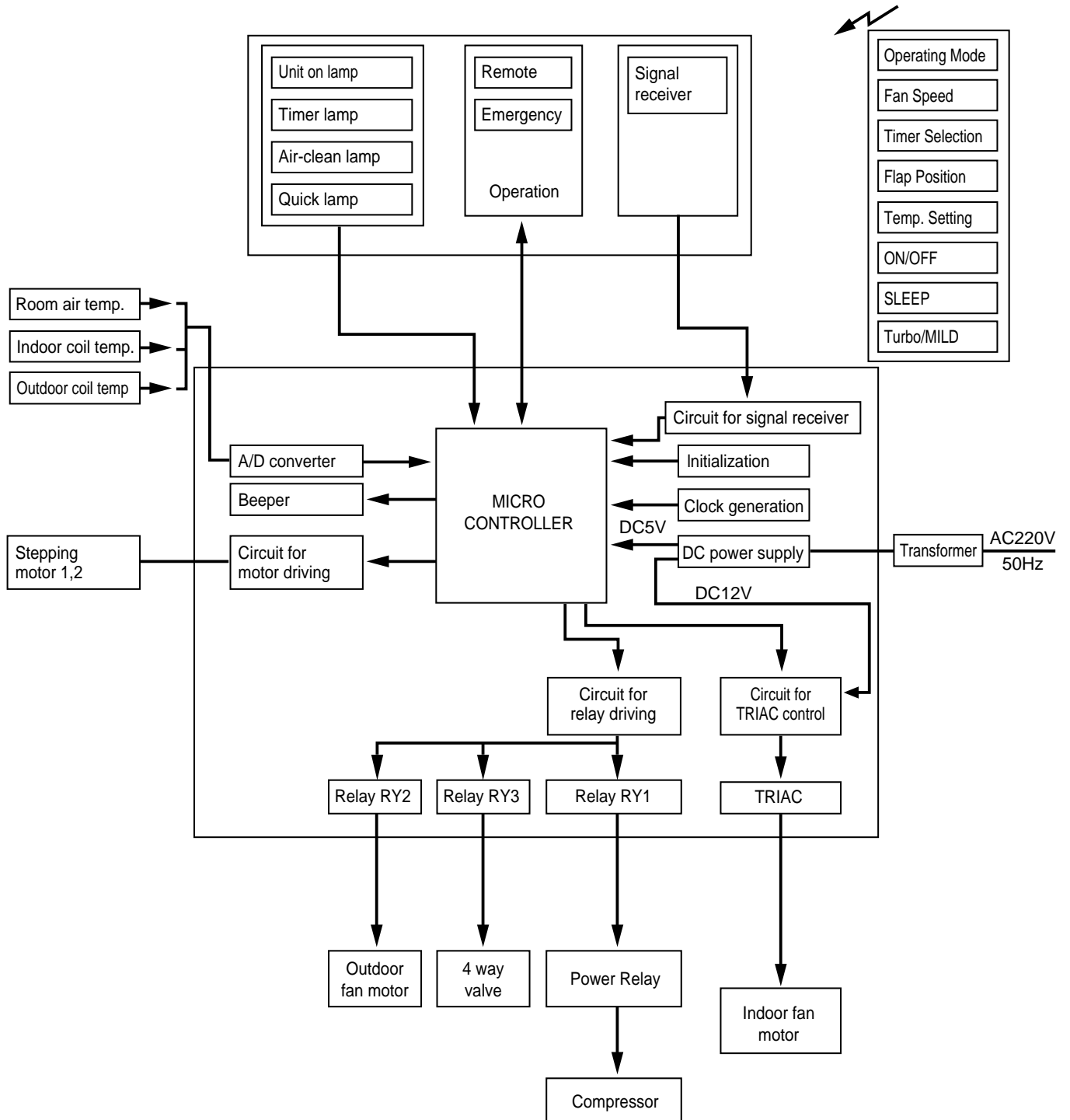

# 7. ELECTRIC CIRCUIT DIAGRAM

## 1 ELECTRIC CIRCUIT DIAGRAM

◆ DSB-181LH

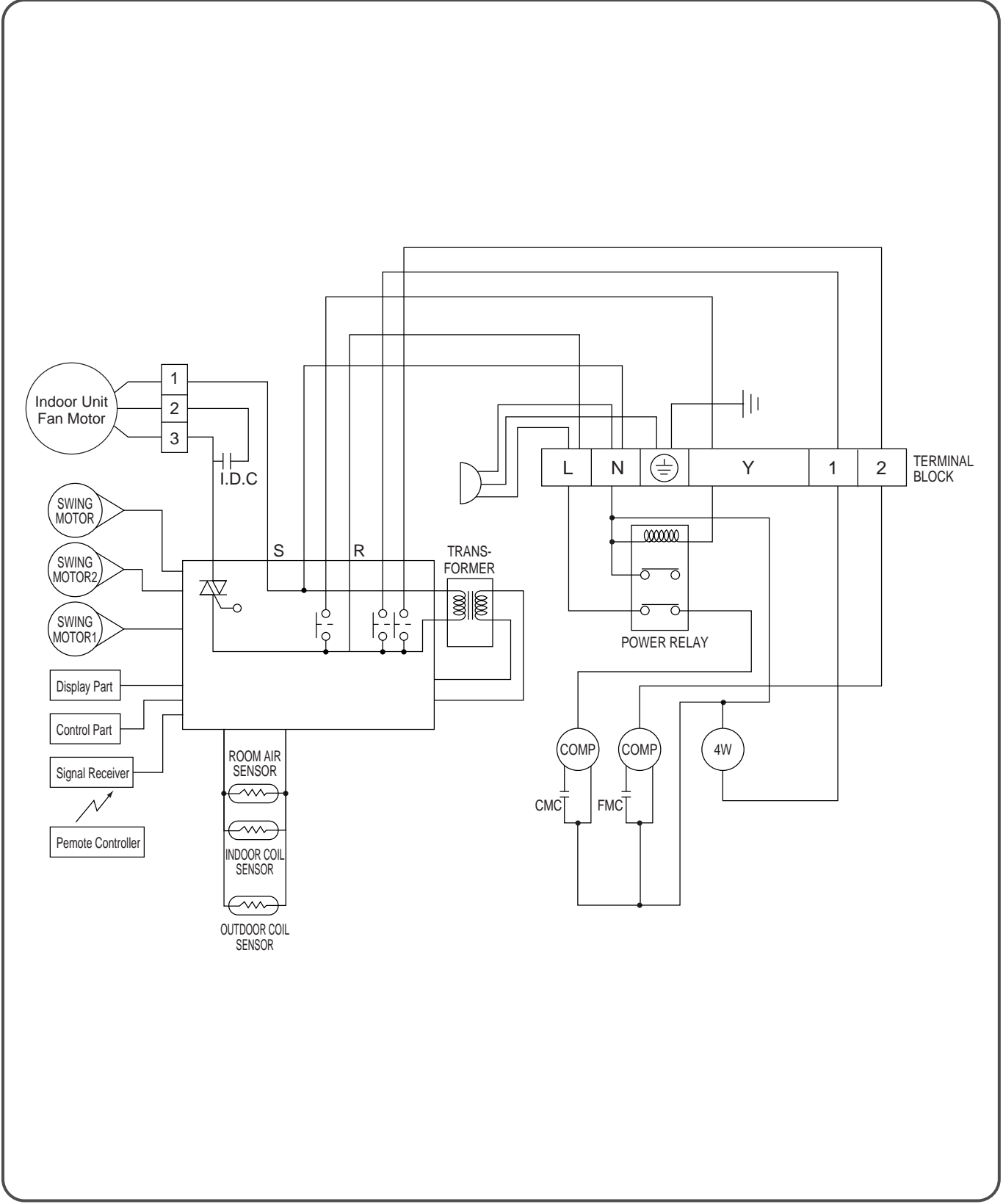

## Description

1. After the power ON/OFF button is pressed once, the relay and triac are turned ON or OFF per the remote control setpoint.
  - TRIAC is controlled per the fan speed selection.
  - RELAY is controlled per the operation mode selection.
2. If the power ON/OFF button is pressed once more, the relay and triac are turn off and the unit stops operation.
3. The unit turns on or off according to the temperature set point by sensing the room air temperature through thermistor.
4. If the fan speed selection is set to the auto position, the fan speed is automatically controlled according to the temperature difference between room temperature and temperature set point.

## 2 PCB CIRCUIT DIAGRAM

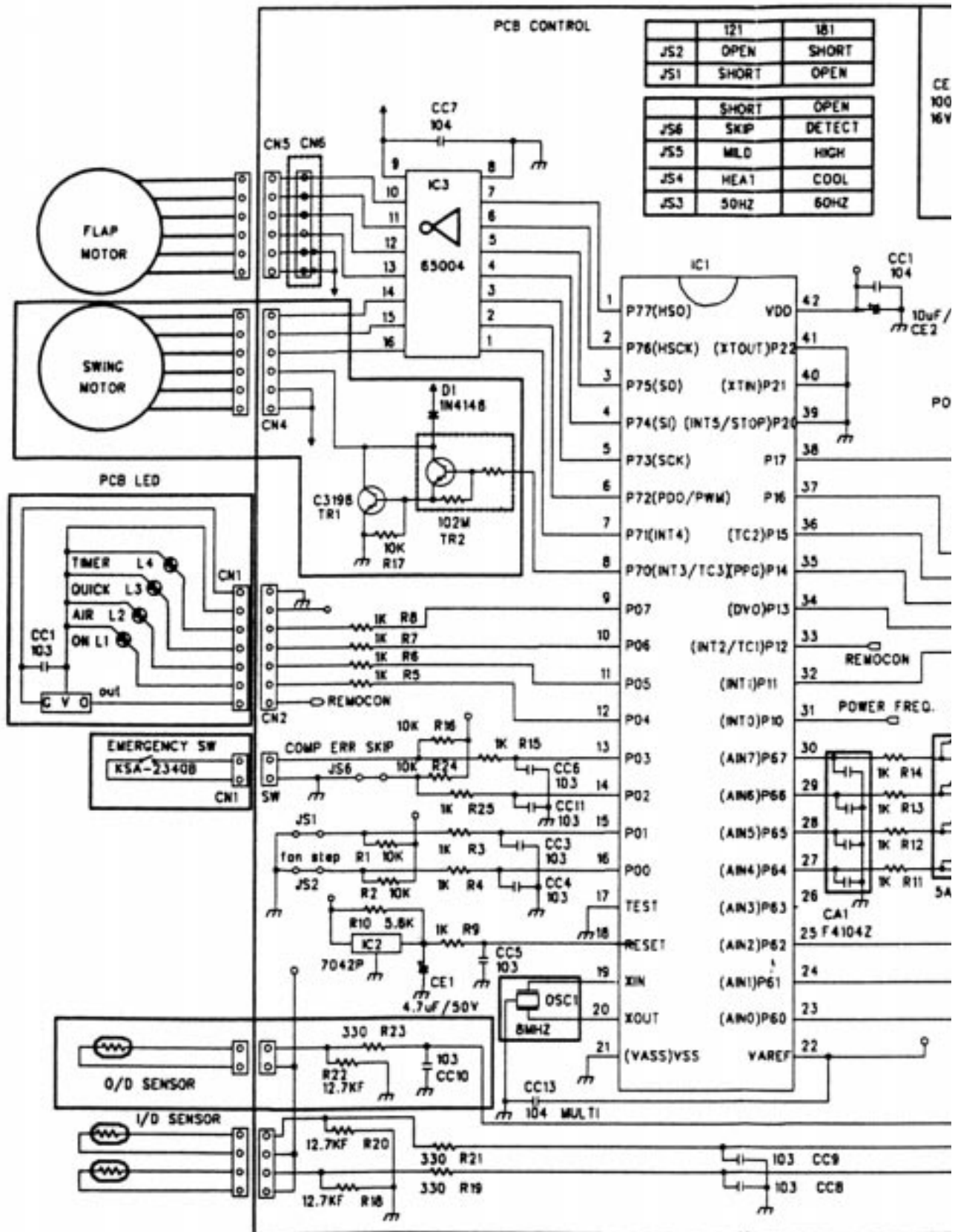

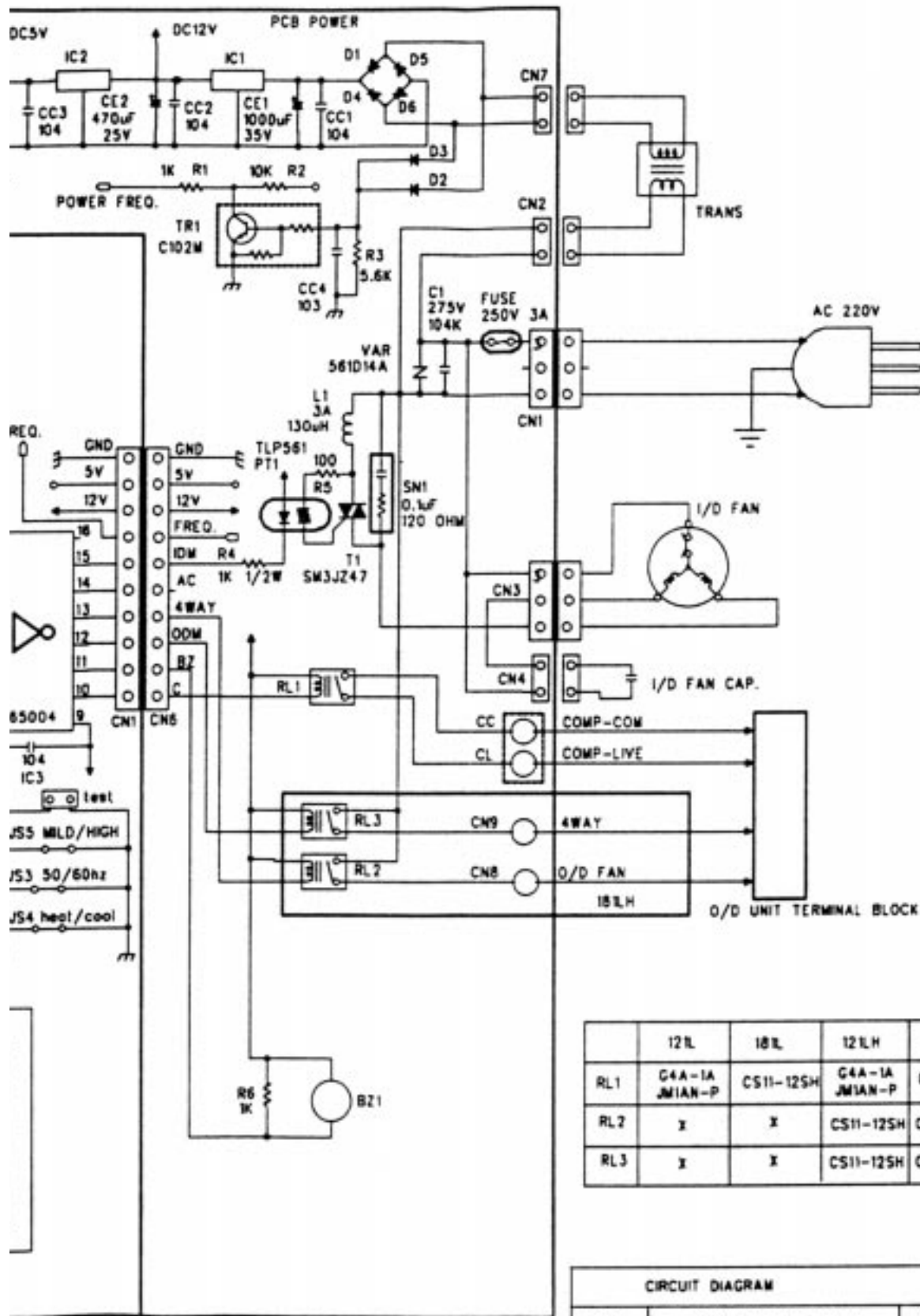

	12R	18R	12LH	18LH
RL1	G4A-1A JM1AN-P	CS11-125H	G4A-1A JM1AN-P	CS11-125H
RL2	X	X	CS11-125H	CS11-125H
RL3	X	X	CS11-125H	CS11-125H

CIRCUIT DIAGRAM		
MODEL	.DSB-121L/LH.181L/LH	1998.11.

# 8. TROUBLE SHOOTING

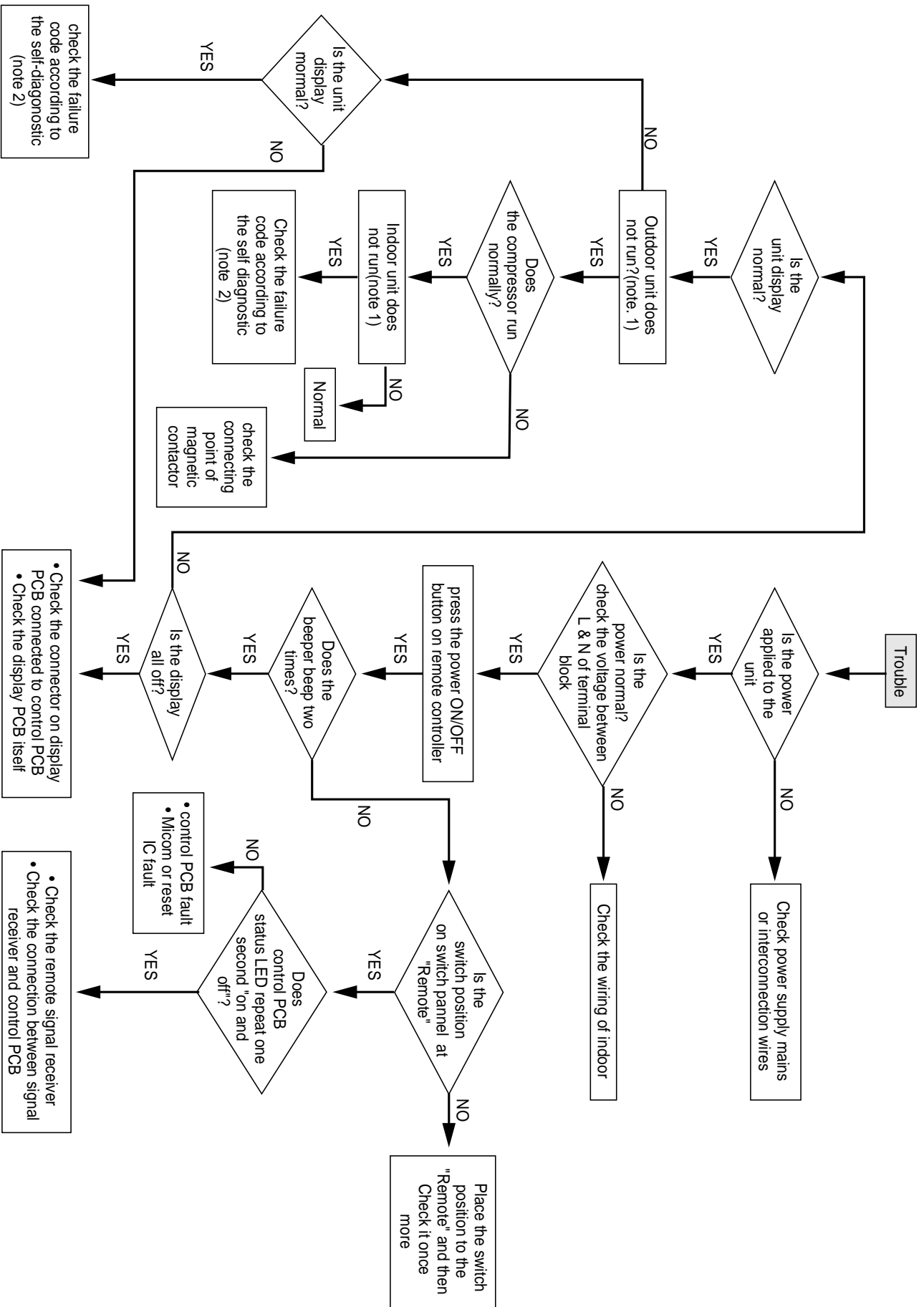

Note 1)

! Neither indoor unit nor outdoor unit runs.

Check the following points first. (There are following case in normal operation)

- a. Is the timer mode set the "timer ON".
- b. Is the timer mode set the "timer-OFF" and the time had passed?

@ Neither outdoor fan nor compressor runs while indoor fan runs.

Check following points first. (There are following cases in normal operation)

- a. Is the temperature set point suitable?
- b. Has the 3 minutes time guard for compressor operated?

Note 2) Please refer to page 25, Self Diagnostic-function

## Self-Diagnostic Function

### 1) Error Code 1

! Check the connector of room air thermistor. (or connecting wire)

- @ Check soldering of connecting on control P.C.B. (Error of soldering or short)
- # Check the resistance of room air thermistor.

### 2) Error Code 3 (Display Emergency Mode)

! When the compressor do not run.

- i) Check the voltage between **N** and **Y** of terminal block.  
(Indoor Unit, Outdoor Unit)
- ii) Check connecting wire of indoor unit and outdoor unit.
- iii) Check relay KI on power P.C.B

- @ Check fixing of indoor coil thermistor.
- # Check the GAS LEAKAGE of the pipe.

## Neither Indoor Unit nor Outdoor Unit Runs

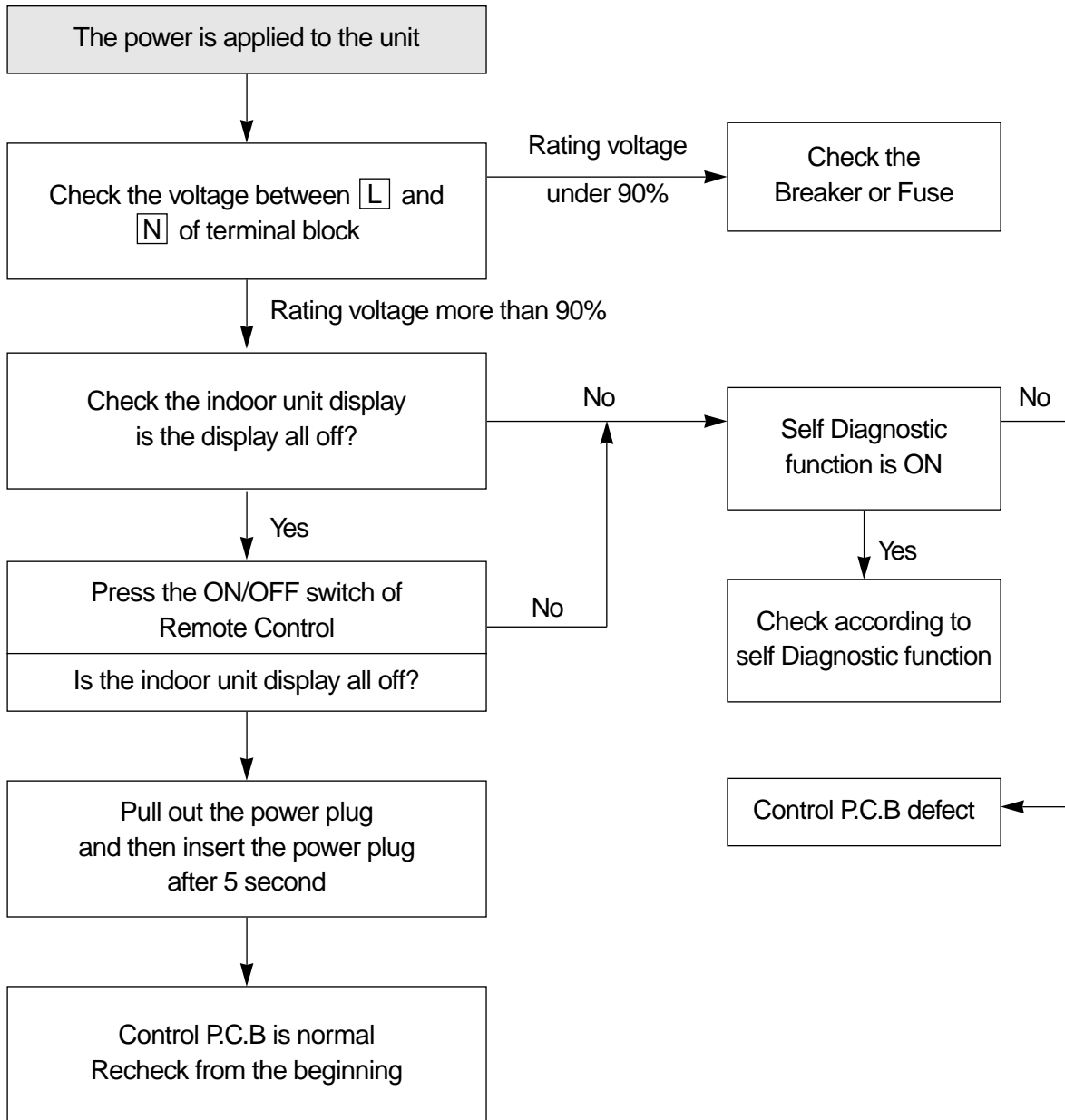

## Outdoor Unit Runs but Indoor Unit Do Not Run

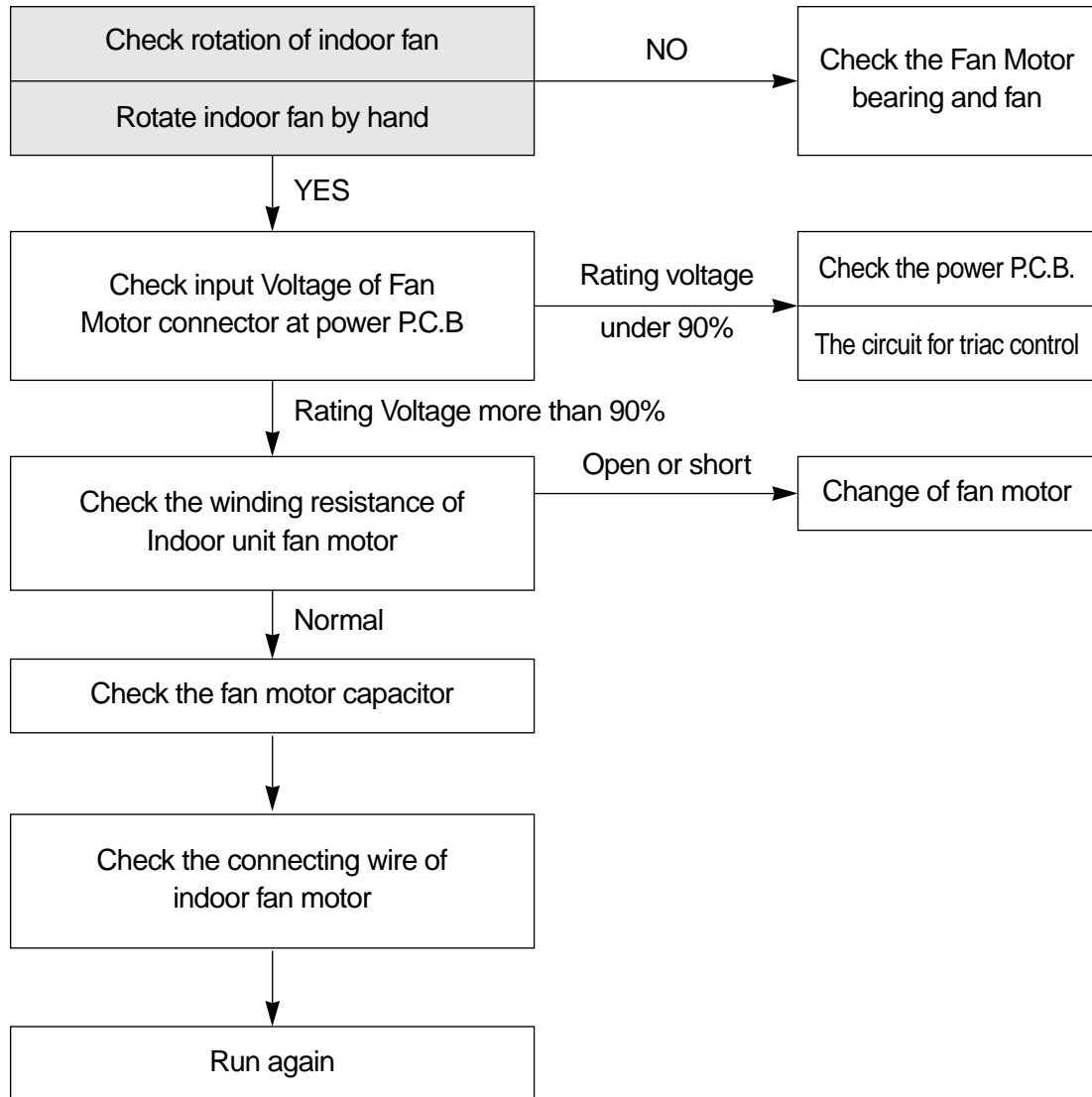

## Outdoor Fan Do Not Run

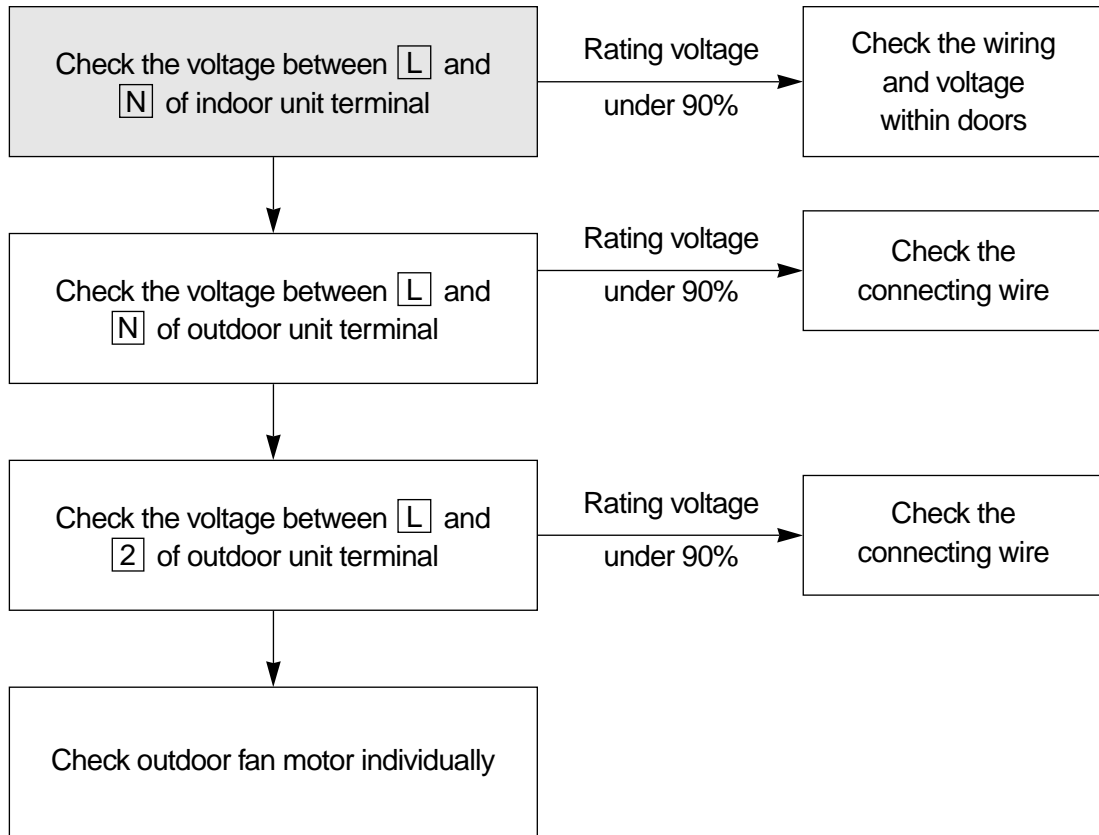

# Only Compressor Do not Run

- Check the following at cooling mode

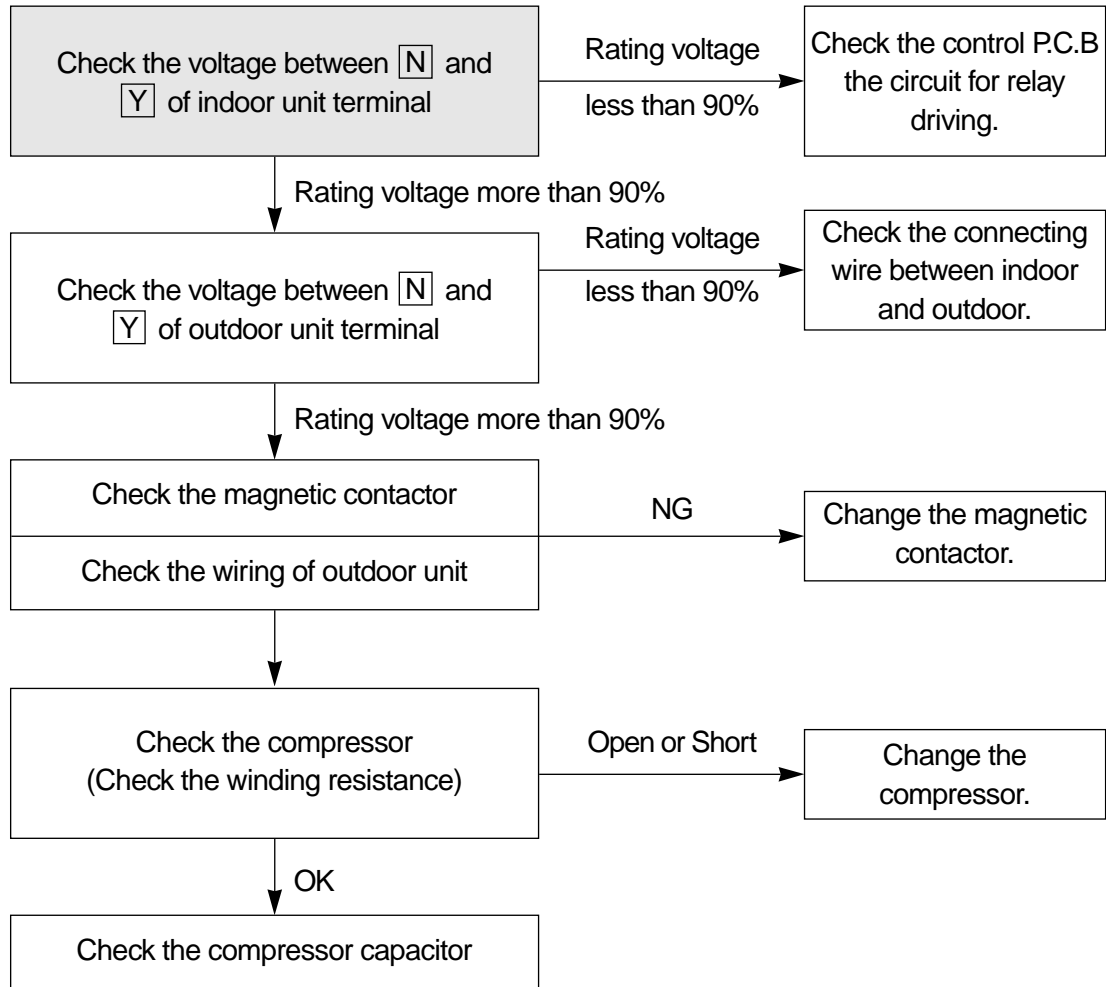



# PCB DRIVING DESCRIPTION

## Power Supply (1)

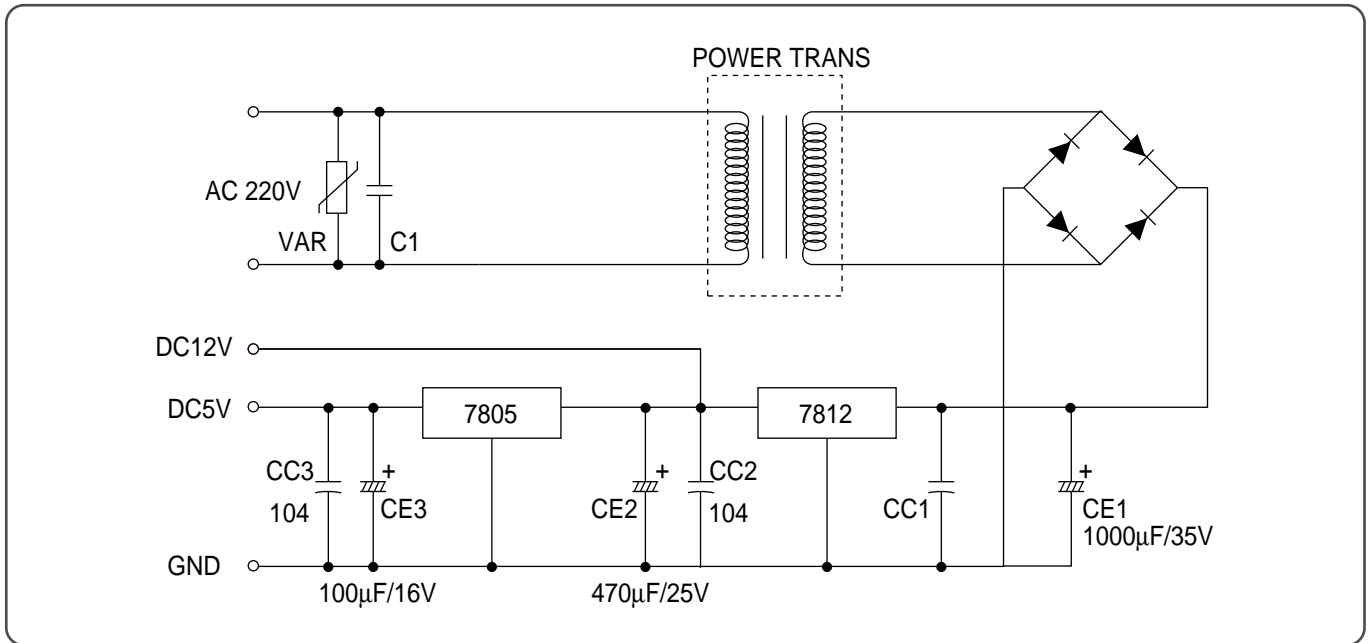

### DESCRIPTION

DC Power Supply in circuit needs +12V and +5V. +12V is used for Compressor Driving Relay, Triac Driving Photo Triac, Buzzer Driving Swing/Sweep Motor, and LED Display. AC voltage of secondary Power Transformer is rectified by Bridge Diode, and it is filtering by Main Condensator CE1.

Filtered DC voltage is about +18V, is regulated +12V DC by Regulator IC7812.

And it is regulated +5V DC by Regulator IC7805.

VAR is serge filter and CC2, CC3, CE2, CE3 is Noise filter.

## Sensor (2)

Room temperature and Evaporator temperature Sensor Input

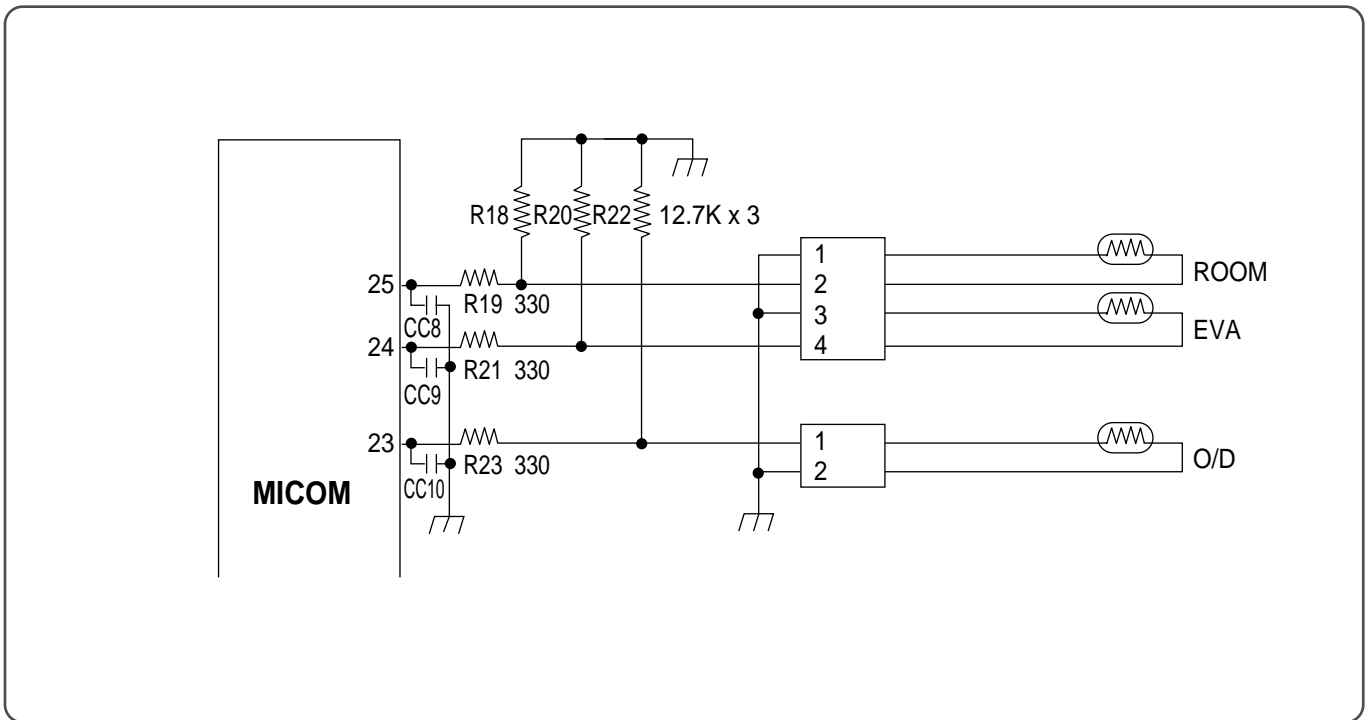

### DESCRIPTION

Number 23, 24, 25 of Micom is Terminal of A/D convertor Input.

Room temperature and Indoor coil, Outdoor coil Temperature is sensing by change of Thermister Resistance, Micom is put in 5V by ratio between R18 (12.7K $\Omega$ ) and R20, R22 (12.7K $\Omega$ ).

Relation between temperature and voltage is following Table 2-1.

CC8, CC9, CC10 is Noise filter.

Temperature (°C)	Voltage (V)
	No. 23, 24, 25
-5	1.12
0	1.37
15	2.22
25	2.79
40	3.52

Table 2-1

## Selecting Mode (3)

(SELECT S/W INPUT, OUTPUT)

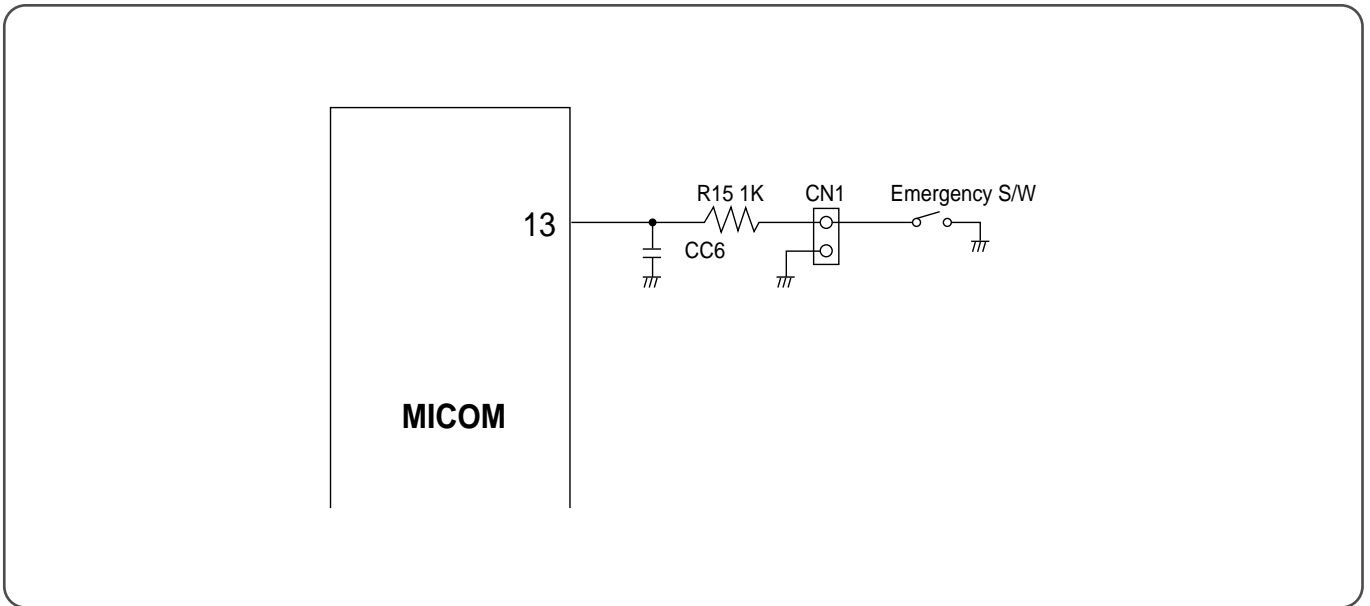

### DESCRIPTION

There are three Mode according to SW position as following Table 3-1.  
According as port of fixed Micom is Low, the unit is operating as following Table 3-1.

POSITION	OPERATING MODE
Open	REMOCON
Close	EMERGENCY

Table 3-1

## Micom Power Supply (4)

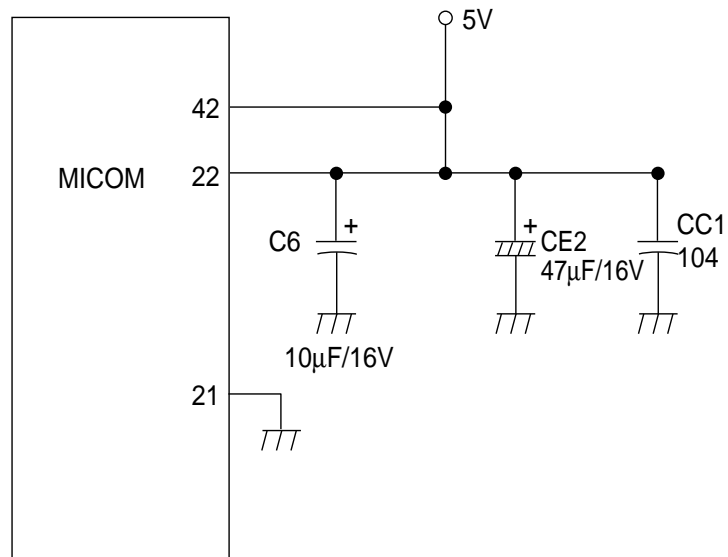

### DESCRIPTION

MICOM Power is supplied 5V at Number 42 using Digital, Number 22 using Reference of A/D Converter. CE2 is Ripple filter and CC1 is Noise filter.

## Reset (5)

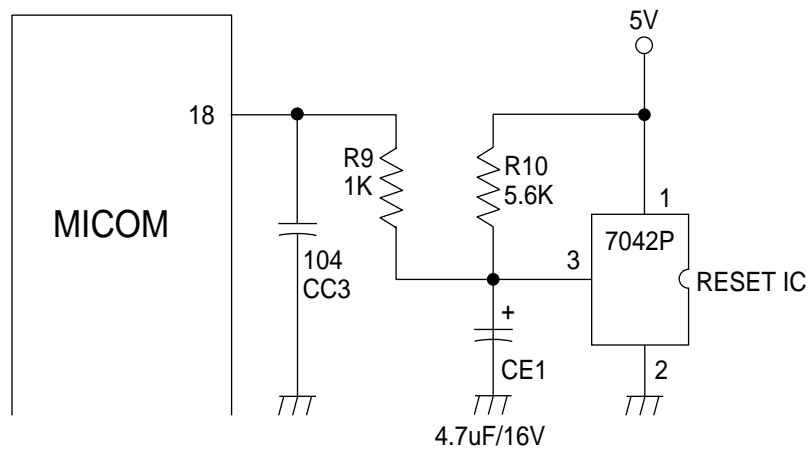

### DESCRIPTION

Voltage less than about 4.2V put in Micom Terminals of Number 18 and then Micom reset. Reset IC detect Power ON and Voltage less than 4.2V, and then send Reset Signal. There is a Manual Reset S/W to reset manually if necessary.

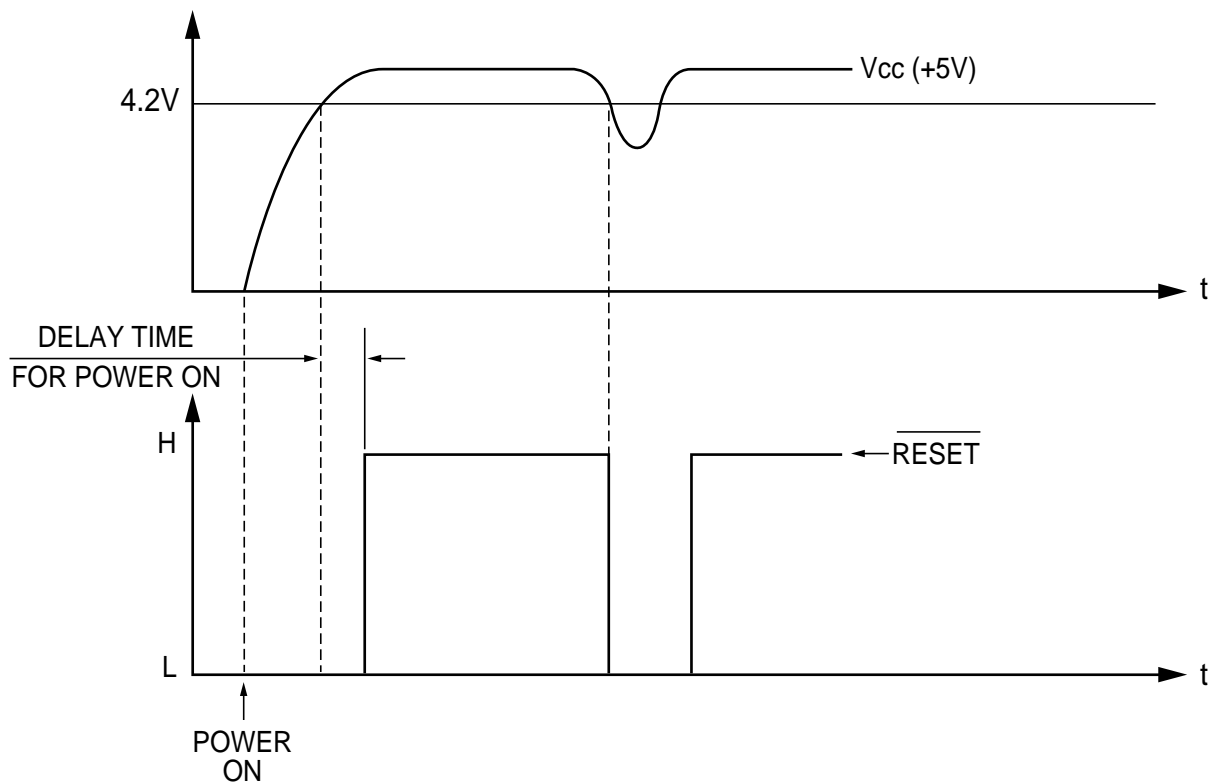

## Buzzer Driving (6)

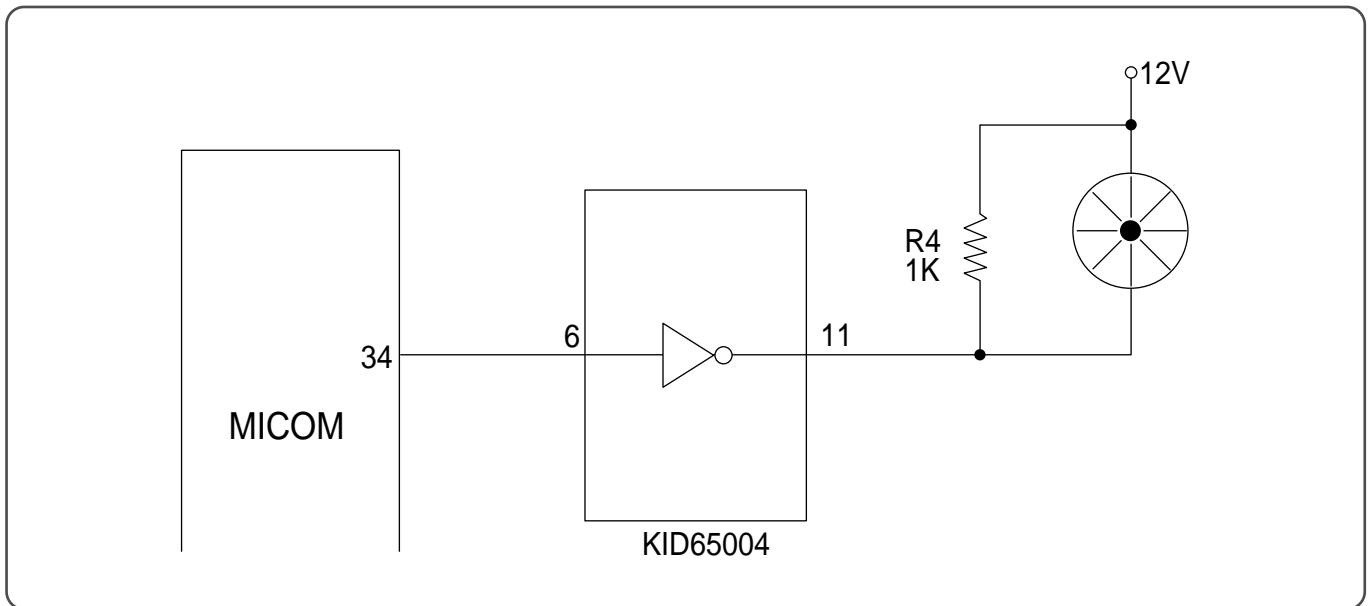

### DESCRIPTION

Micom 15 Terminal put out Buzzer Driving Pulse, its output is driving Buzzer through Buffer.

Oscillatory Frequency of buzzer is selected by internal Micom.

It is set by S/W among 2 KHz, 4.1KHz and 8.2KHz.

This unit is setting at 4.1KHz.

R4 is Resistance to protect excessing current of Buzzer.

## Triac Driving (7)

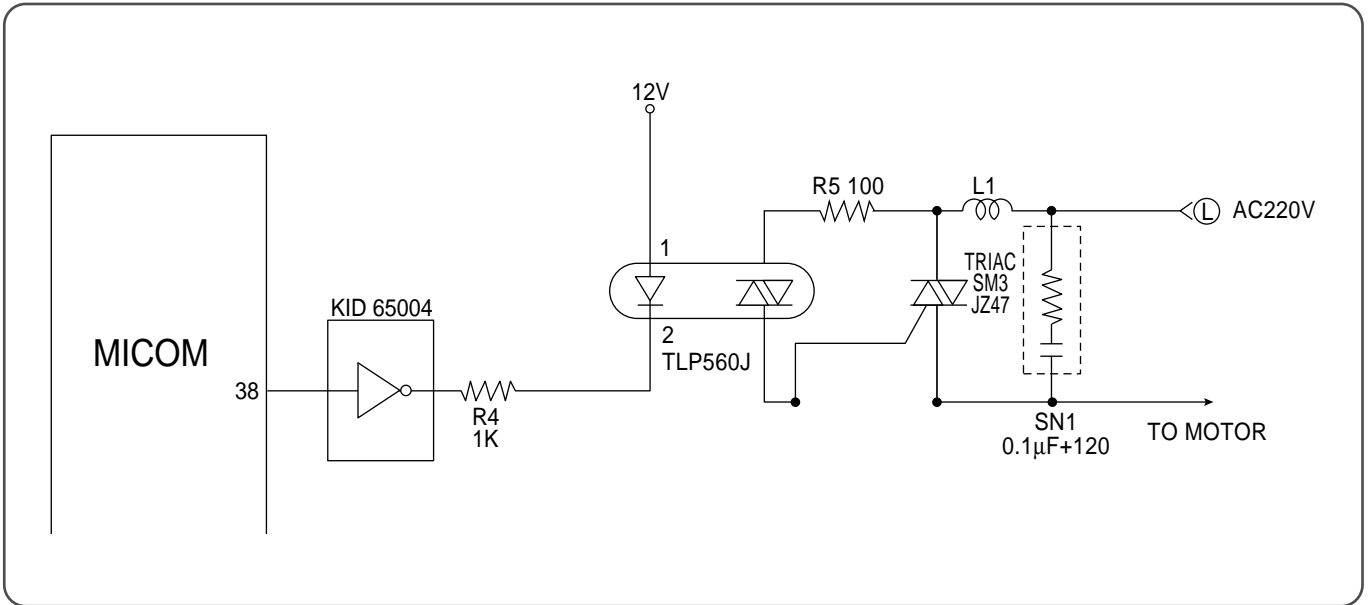

### DESCRIPTION

Number 38 Terminal of Micom is put out Pulse Output, by way of Buffer it is driving Photo Triac K3021PG and then Triac SM3JZ47 is supplied Trigger Signal.

Trigger Test of Triac is detected Zero Cross Part of AC input and it is triggered from Zero Cross part to Time delay part according to Fan Speed. (Ref. Fig 7-1) SN1 is Snubber.

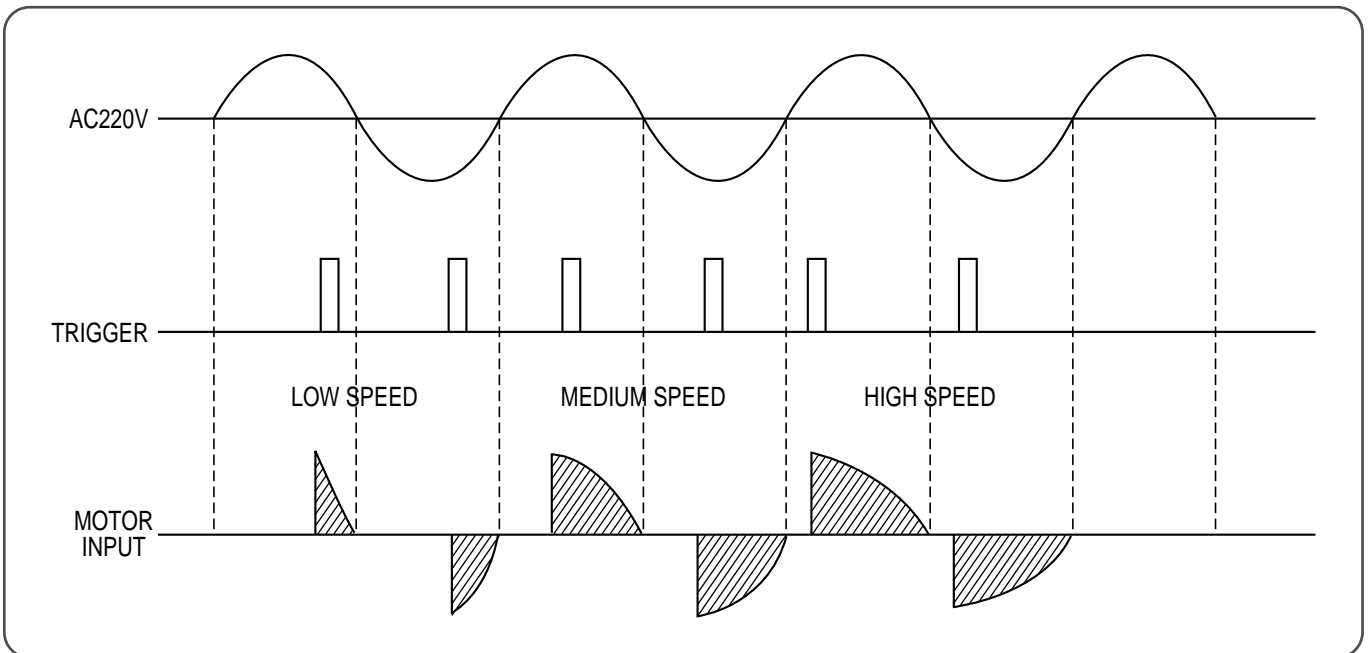
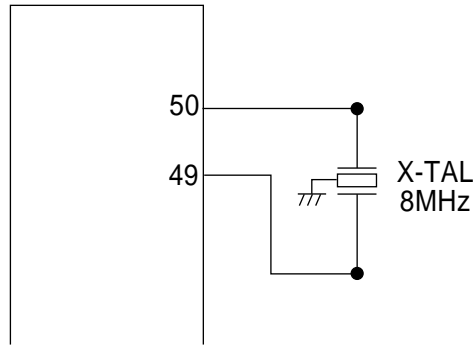

Fig 7-1

## Oscillation (8)



### DESCRIPTION

Oscillatory Frequency drive Micom, it is made up 8MHz X-TAL oscillatory Frequency.  
Oscillatory wave is as following Fig 9-1.

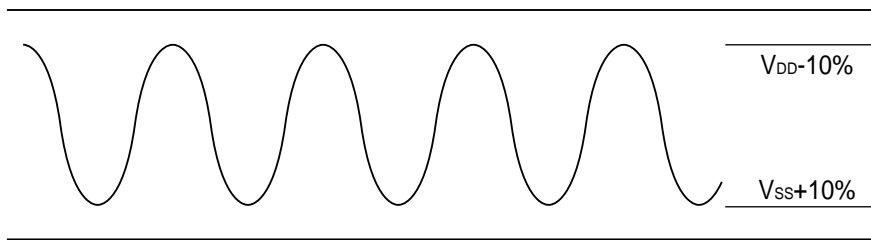
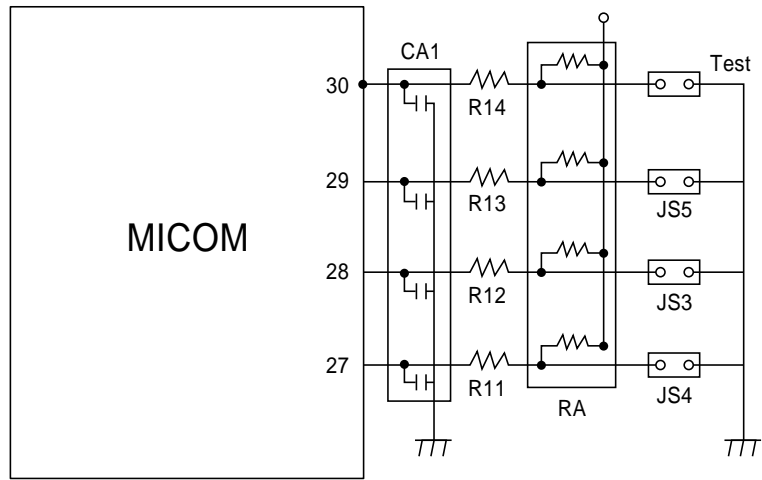

Fig 9-1

## Functional Configuration (9)





Selecting Function is as following Table

	SHORT	OPEN
JS6	Skip	Comp err detect
JS5	Mild	High
JS4	Heat	Cool
JS3	50Hz	60Hz

# 9. DISASSEMBLY INSTRUCTIONS

## 1 INDOOR UNIT

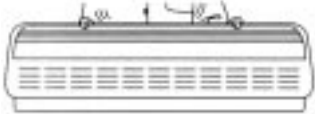
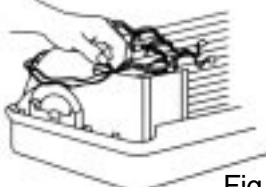
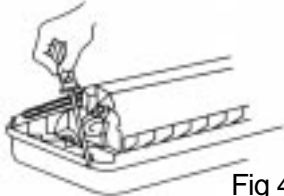

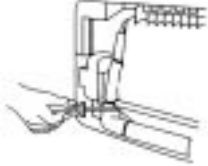
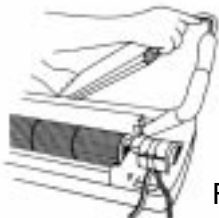

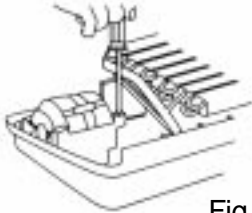
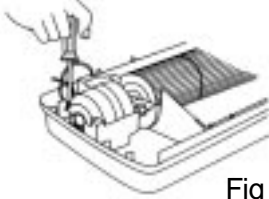
i DSB-181LH

PROCEDURES	PHOTOS
<p>1. Stop the Air conditioner and disconnect the power cord from the wall outlet.</p>	
<p>2. Removing the insert Grille and Frame.                      !Loosen three screws for fixing the the Insert Grille and Frame.                      (Pull out the frame cap before loosening three screws) (Fig 1)                      @ Loosen three screws at the Drain Pan.                      # Remove the Insert Grille and Frame.</p>	<p>Fig 1</p>  <p>Fig 2</p>
<p>3. Removing the Control Box.                      After doing above procedures:                      !Disconnect indoor room and coil thermistors. (Fig 3)                      @ Disconnect the fan motor lead wire from connection at the main PCB. (Fig 3)                      # Disconnect the swing motor connection wire.                      \$ Loosen a screw for fixing ground wire.                      % Loosen two screws for fixing the body.</p>	 <p>Fig 3</p>
<p>4. Removing the Drain Pan.                      After doing above procedures:                      !Loosen a screw for fixing body. (Fig 4)                      @ Unhook the right part of Drain Pan.</p>	 <p>Fig 4</p>
<p>5. Removing the Indoor Coil.                      After doing above procedures:                      !Loosen four screws for fixing indoor coil at left and right side. (Fig 5)                      @ Loosen a screw for fixing the bracket tube at the back side. (Fig 6)                      # Remove the indoor coil. (Fig. 6-1)</p>	 <p>Fig 5</p>  <p>Fig 6</p>
<p>6. Removing the fan motor.                      After doing above procedures:                      !Loosen two screws for fixing holder moter at left and right side.                      (Fig 7, 8)                      @ Loosen a screw for fixing fan motor and blower.                      # Remove the fan motor.</p>	 <p>Fig 6-1</p>

PROCEDURES	PHOTOS
<p>7. Removing the blower.</p> <p>After doing above procedures:</p> <ul style="list-style-type: none"><li>! Loosen a screw for fixing holder bearing.</li><li>@ Remove the blower.</li></ul>	 <p>Fig 7</p>  <p>Fig 8</p>

## 2 OUTDOOR UNIT

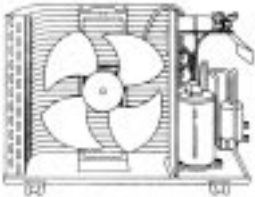
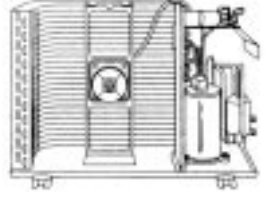
i DSB-181LH

PROCEDURES	PHOTOS
<p>1. Basic Procedures</p> <ul style="list-style-type: none"> <li>! Stop the air conditioner and pull out power plug from wall outlet.</li> <li>@ Remove CABINET TOP COVER. (Loosen ten screws)</li> <li># Remove CABINET SIDE COVER. (Loosen six screws)</li> <li>\$ Remove CABINET FRONT. (Loosen six screws)</li> </ul>	 <p>Fig 1</p>
<p>2. Removing Fan Motor (Fig 4)</p> <ul style="list-style-type: none"> <li>! Do basic procedure. ( !-\$ )</li> <li>@ Loosen nut for fixing fan by spanner.</li> <li># Remove spring washer and plain washer.</li> <li>\$ Remove fan.</li> <li>% Remove fan stopper.</li> <li>^ Disconnect Motor lead wire from control box.</li> <li>&amp; Loosen four screws for fixing Motor bracket and then remove the Motor.</li> </ul>	 <p>Fig 2</p>  <p>Fig 3</p>
<p>3. Removing Dual Capacitor</p> <ul style="list-style-type: none"> <li>! Do basic procedure. ( !-\$ )</li> <li>@ Disconnect lead wire from the Dual capacitor.</li> <li># Loosen two screws for fixing the capacitor bracket.</li> <li>\$ Remove the Dual capacitor</li> </ul>	 <p>Fig 4</p>
<p>4. Removing Magnetic Contactor. (Fig 5)</p> <ul style="list-style-type: none"> <li>! Do basic procedure !-\$@ .</li> <li>@ Disconnect lead wire from Magnetic Contactor.</li> <li>! Remove Magnetic contactor. (Loosen four screws)</li> </ul>	 <p>Fig 5</p>

### 3 EXPLODED DIAGRAM (Indoor Unit)

i DSB-181LH

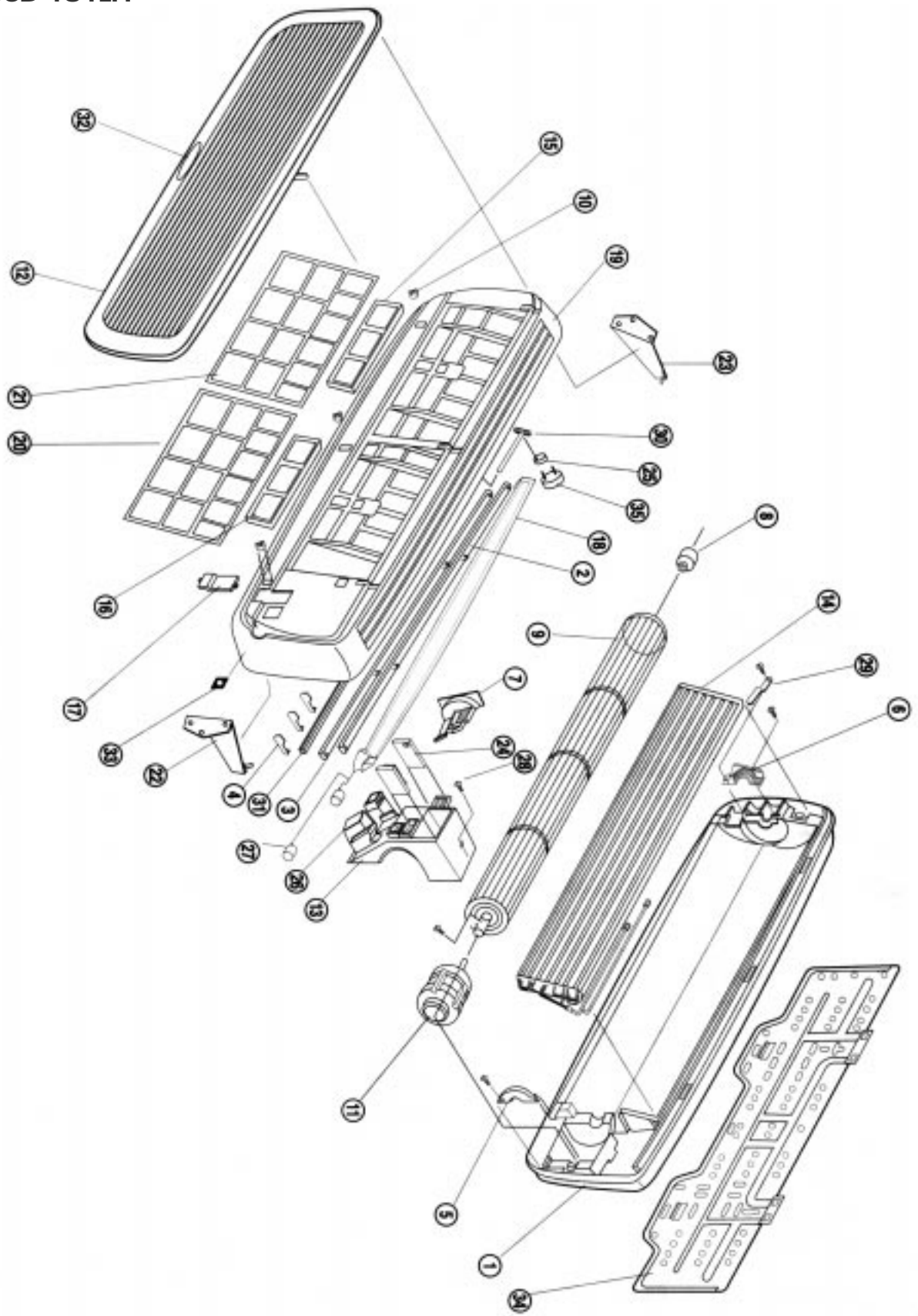

## i DSB-181LH Parts List (Indoor Unit)

No	PART CODE	PART NAME	Q'TY	SPEC	REMARK
1	3100400101	BODY	1	ABS	
2	3107600100	FLAP TOP	1	ABS	
3	3107600200	FLAP UNDER	1	ABS	
4	3106500400	BLADE VERTICAL	16	ABS	
5	3103000500	HOLDER MOTOR R	1	ABS	
6	3103000700	HOLDER BEARING	1	ABS	
7	3103000600	HOLDER MOTOR L	1		
8	3106400100	BEARING OILESS	1		
9	3101800200	FAN CROSS FLOW	1	Ø100X861L	
10	3102400800	GRILLE LATCH	3	POM	
11	3108000311	MOTOR FCU	1	IC-9425 DWKC 5A	
12	3102400900	INSERT GRILLE	1	ABS	
13	3100501000	BOX CONTROL	1	ABS	
14	3107400010	EVAPORATOR ASS'Y	1		
15	3101930000	FILTER ELECTRO ASS'Y	1		
16	3101940000	FILTER CARBON ASS'Y	1		
17	3101403700	COVER TERMINAL BLOCK	1	ABS	
18	3108100100	PAN DRAIN	1	ABS	
19	3102200200	FRAME	1	ABS	
20	3101910000	FILTER PRE R ASS'Y	1		

No	PART CODE	PART NAME	Q'TY	SPEC	REMARK
21	3101920000	FILTER PRE L ASS'Y	1		
22	3102900500	HINGE R	1	POM	
23	3102900600	HINGE L	1	POM	
24	3104300100	CONTROL PCB ASS'Y	1		
25	3107800100	LINK VER CAM	1	P.O.M	
26	3104300300	LED PCB ASS'Y	1		
27	3108000100	MOTOR STEPPING	2	MP28GA	l=400mm
28	3108912330	TERMINAL BLOCK	1	DBW-6P	
29	3107400300	EVA BRKT L	1	SECC T1.0	
30	3107800200	LINK VER A	1	ABS	
31	3107800400	LINK VER C	1	ABS	
32	3107500200	EMBLEM	1	URETAN	
33	3105500200	PLATE WINDOW SWITCH	1		
34	3104500300	PLATE MOUNTING	1	SECC T0.8	
35	3108000200	MOTOR STEPPING	1	MP28GA	l=1300mm
36	3104300200	POWER PCB ASS'Y	1		
37	3104300400	SWITCH PCB ASS'Y	1		

# 4 EXPLODED DIAGRAM (Outdoor Unit)

i DSB-181LH

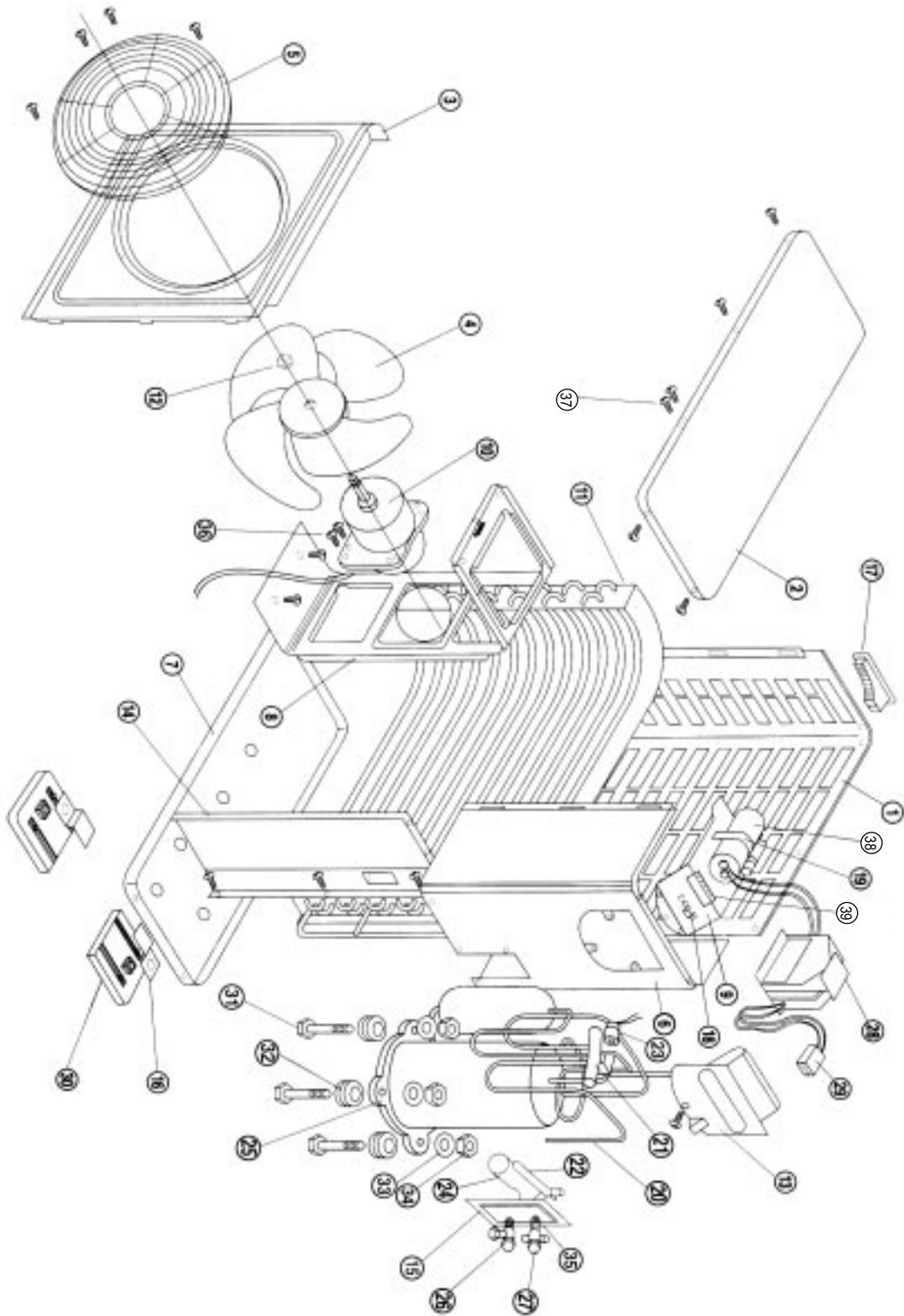

## i DSB-181LH Parts List (Outdoor Unit)

No	PART CODE	PART NAME	Q'TY	SPEC	REMARK
1	3100800101	CABINET BACK	1	SECC T1.0	
2	3104200500	PANEL TOP	1	SECC T1.0	
3	3100800201	CABINET FRONT	1	SECC T1.0	
4	3101800100	FAN PROPELLER	1	ABS+G/F	
5	3102400710	GRILLE DISCHARGE	1	PP	
6	3100800301	CABINET SIDE	1	SECC T1.0	
7	3100300301	PAN BASE	1	SECC T1.6	
8	3105300100	SUPPORTER MOTOR	1	SECC T1.0	
9	3104200601	PANEL CONTROL	1	SECC T1.0	
10	3108000400	MOTOR ODU	1	220V/50Hz	
11	3106800030	CONDENSER ASS'Y	1		
12	7392800011	NUT HEX	1	M8	
13	3102600101	HANDLE R	1	PP	
14	3104500601	PLATE PARTITION	1	SECC T1.0	
15	310061000P	BRACKET SERVICE ASS'Y	1		
16	3102100200	FOOT	4	SECC T2.0	
17	3102600200	HANDLE L	1	PP	
18	3101200310	CLAMP CORD	2		
19	3101200100	CLAMP CAPACITOR	1	SECC T0.8	
20	3100003200	PIPE REVERSING ASS'Y	1	CU <sub>φ</sub> " , φ "	

No	PART CODE	PART NAME	Q'TY	SPEC	REMARK
21	3105400300	REVERSING VALVE	1	V2-100	
22	3100003000	PIPE FILTER ASS'Y	1	CU	
23	3109700100	SOLENOID COIL	1	L30-0240	
24	3100003100	CAPILLARY ASS'Y	1	CU ¼β"	
25	3107130000	COMPRESSOR ASS'Y	1	220-240V 50Hz	
26	3105400210	SERVICE VALVE	1	¼ø"	
27	3105400100	SERVICE VALVE	1	¼ "	
28	5SC0202700	POWER RELAY	1	G7L-2A-TUB	
29	3100003400	COIL SENSOR ASS'Y	1		
30	3102100700	FOOT CUSHION	4	NR	
31	3106000900	COMP BOLT	3	M8 x L46.5	
32	3101500700	RUBBER CUSHION	3	NR	
33	7400208411	WASHER PLAIN	3	M8	
34	7392800011	NUT HEX	3	M8	
35	7347602011	BOLT HEX	4	M6 x L20	
36	7348602011	BOLT HEX	4	M6	
37	7112401214	SCREW TAPPING	10	M4	
38	3109500900	CAPACITOR DUAL	1	400VAC 30/3µF	
39	3108912330	TERMINAL BLOCK	1	SN-DBW-6P	



## i DSB-181LH Parts List (Control Box Assembly)

No	PART NAME	SPEC	Q'TY	PART CODE	REMARK
1	CONTROL BOX ASS'Y	DSB-181LH	1	3100058300	
2	BOX CONTROL-2	ABS (VERSION2)	1	3100506900	
3	PCB TRANS ASS'Y	DWA-220V	1	5EPV633110	
4	SCREW TAPPING	T2S TRS 4X12 MFZN	3	7122401211	
5	CAPACITOR IDM	EAF-45125 (1.2 $\mu$ F/450V)	1	3106900210	
6	SCREW TAPPING	T2S TRS 4X24 MFZN	1	7141402411	
7	HARNESS TH3	UL2464-#22	1	3102702200	
8	TERMINAL BLOCK	SN-DBW-6P	1	3108912330	
9	SCREW TAPPING	T2S TRS 3X16 MFZN	2	7111301611	
10	HARNESS POWER	UL 1015 #16/18	1	3102704010	
11	HARNESS EARTH	UL 1015 #18	1	3102797910	
12	HARNESS COMP SIGNAL	UL 1015 #18	1	3102704410	
13	HARNESS REVER VALVE	UL 1015 #18	1	3102704420	
14	HARNESS OD SIGNAL	UL 1015 #18	1	3102704430	
15	POWER CORD	WS-93(250V 10/16A)	1	31013A24B1	
16	CABLE CORD	DA-5N	1	3101200300	
17	CONTROL PCB ASS'Y	DSB-181LH(HEAT PUMP/50Hz)	1	3104300100	
18	HARNESS CONNECTING	UL 1007 #26	1	3102704900	
19	POWER PCB ASS'Y	DSB-181LH	1	3104300200	
20	LED PCB ASS'Y	15/18K (FR-4)	1	3104300300	
21	SWITCH PCB ASS'Y	15/18K (FR-4)	1	3104300400	
22	SENSOR ID ASS'Y	PEM-KD43C-D1	1	3104896000	
23	HARNESS LED PCB	UL 1007 #26	1	3102704510	
24	HARNESS SWITCH PCB	UL 1007 #26	1	3102707000	
25	KNOB SWITCH	ABS	1	3103400200	

**DAEWOO**

**DAEWOO ELECTRONICS CO., LTD.**

686, AHYEON-DONG MAPO-GU SEOUL, KOREA

C.P.O. BOX 8003 SEOUL, KOREA

TELEX: DWELEC K28177-8

CABLE: "DAEWOOELEC"

FAX: 02) 360-8184

TEL: 02) 360-8182/8178~9

<http://www.dwe.daewoo.co.kr>

PRINTED DATE: APR.1999

**DAEWOO**

# Service Manual

SPLIT SYSTEM AIR CONDITIONER

Model: DSB-181LH



**DAEWOO ELECTRONICS CO., LTD.  
OVERSEAS SERVICE DEPT.**

# ABOUT THIS MANUAL

VISION CREATIVE, INC.

51526  
16^

MODEL	DSB-181LH			TEL	(0335)329-8225
BUYER					
	1'	99.4.9	6'		
	2'	99.4.16(...)	7'		
	3'	99.4.20(...)	8'		
	4'		9'		
	5'		10'		
MEMO	<p>MEMO</p> <p>11P</p>				

VISION CREATIVE, INC.  
TEL: 757-9340 FAX: 774-1039