



Contents

CONTENTS

| | |
|---|----|
| 1. Specifications | 2 |
| 2. Operation | 3 |
| 3. Wiring Diagram | 10 |
| 4. Refrigerant Cycle | 11 |
| 5. Control Block Diagram | 12 |
| 6. Circuit Diagram | 13 |
| 7. Trouble Shooting..... | 16 |
| 8. Key Components of Electronic Circuit | 26 |
| 9. Disassembly Instructions | 28 |
| 10. Exploded Diagram and Parts List..... | 29 |

1. SPECIFICATIONS

| ITEM | MODEL | DWA-180R |
|-------------------------|---------------------|----------------------|
| Power Source | V/Hz | AC 220V/60Hz |
| Cooling Capacity | Btu/h | 17,500 |
| | Kcal/h | 4,410 |
| Energy Efficiency Ratio | Btu/wh | 9.0 |
| | Kcal/wh | 2.3 |
| Dehumidification | L/h | 2.0 |
| Electrical Data | Power Input(W) | 1,900 |
| | Running Current(A) | 9.0 |
| Compressor | Type | Rotary |
| | Model | QJ250KD24A |
| | Capacitor | AC 400V, 30 μ F |
| Fan Motor | Model | IC-12640DWWF6A |
| | Capacitor | AC 400V, 6 μ F |
| | Indoor-Fan | Blower Fan |
| | Outdoor-Fan | Propeller Fan |
| Refrigerant(R-22) | Control | Capillary |
| | Charge Amount (g) | 970g |
| Dimensions | Unit (W x H x D) | 660 x 430 x 705 (mm) |
| | Packing (W x H x D) | 711 x 525 x 757 (mm) |
| Weight | Net Weight (Kg) | 52.5 |
| | Gross Weight (kg) | 57.5 |

2. OPERATION

1 PARTS OF NAME AND FUNCTION

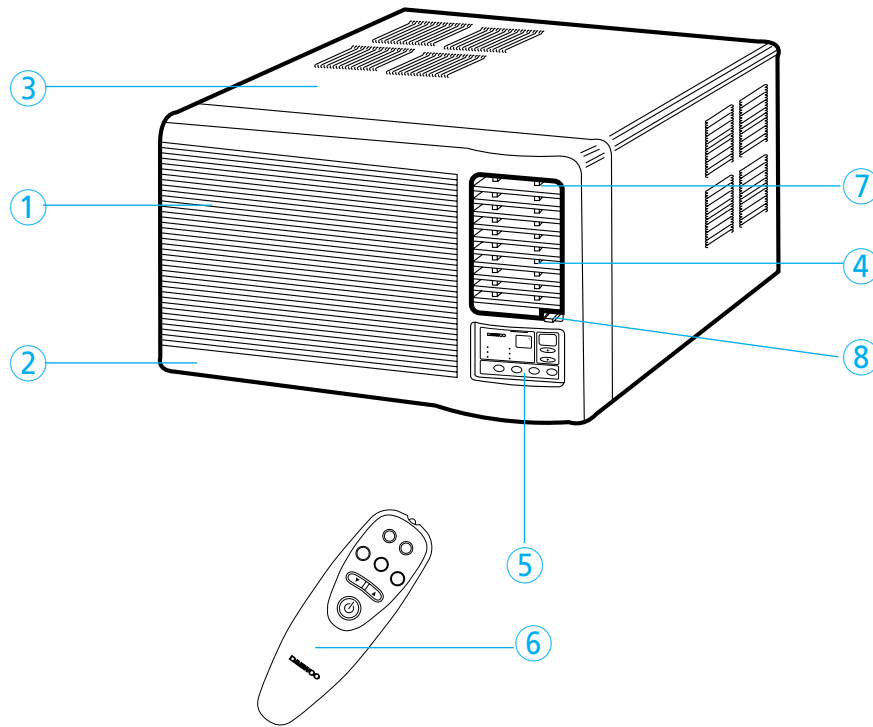

| NO | PART NAME | NO | PART NAME |
|----|----------------|----|-------------------|
| 1 | AIR FILTER | 5 | PANEL CONTROL |
| 2 | GRILLE FRONT | 6 | REMOTE CONTROLLER |
| 3 | CABINET | 7 | BLADE HORIZONTAL |
| 4 | BLADE VERTICAL | 8 | AIR VENT |

2 REMOTE CONTROLLER

REMOCON SIGNAL TRANSMITTER

TIMER/CANCEL

- Everytime you push this button, timer is set as follow.
(1Hr→2Hr→3Hr→4Hr→5Hr→6Hr→8Hr→10Hr→12Hr→16Hr→20Hr→24Hr→CANCEL).
- After the unit is timed, if this button is pushed, timer is canceled.

FAN SPEED

- Everytime you push this button, it is selected as follow.
(High→Mid→Low→High)

TEMPERATURE

- It is the button to set the room in the desired room temp.
The temp can be set within a range from 16°C (60°F) to 32°C (90°F) by 1°C (1°F)

POWER ON/OFF

- To turn the unit ON, push this button. To turn the unit OFF, push this button, again.

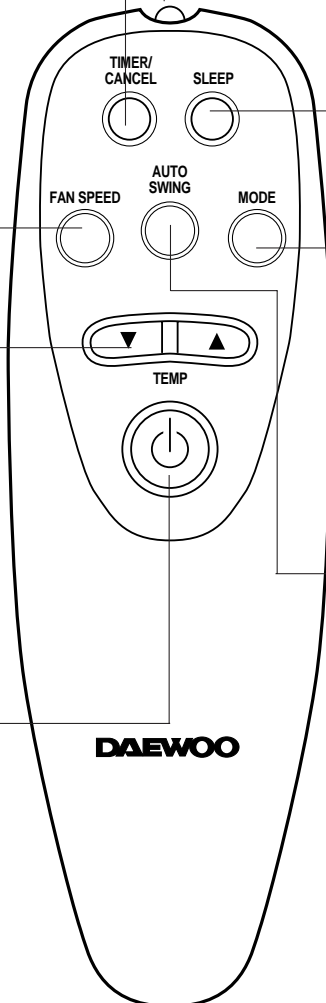

SLEEP

- SLEEP mode is selected as follow. (L1→L2→Cancel)

MODE

- Everytime you push this button, it is selected as follow.
(COOLING→TURBO→FAN→COOLING)

AUTO SWING

- Everytime you push this button, the auto swing mode is toggled.

* Do not use the REMOTE CONTROLLER before the lamp lights. If use, the "°F" temperature display can change to "°C" temperature display (only "°F" temperature display model).

3 REMOTE CONTROLLER DISPLAY

MODE DISPLAY

- It displays the operating mode.

TEMP./TIMER DISPLAY

- It displays the temperature and the timer.

REMOCON SIGNAL RECEIVER

TEMPERATURE SET BUTTON

- It is the button to set the desired room temperature.
The temperature can be set within a range from 16°C (60°F) to 32°C (90°F) by 1°C (1°F)

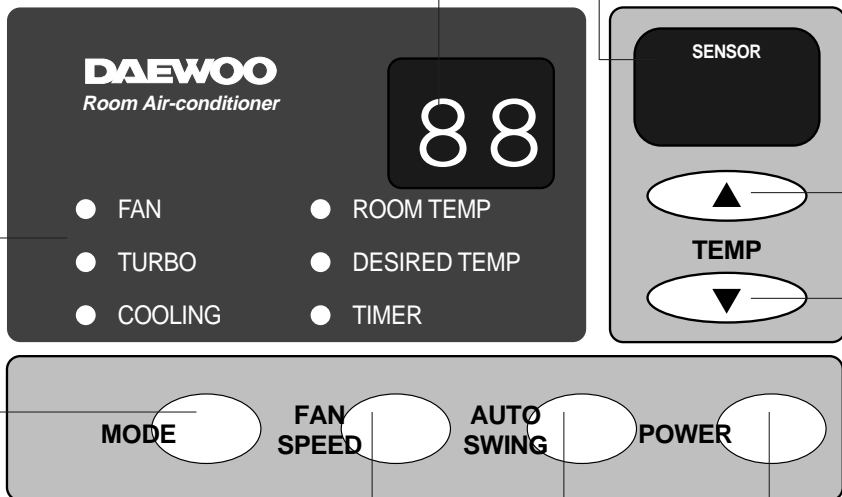

FAN SPEED BUTTON

- Everytime you push this button, It is selected as follow. (High→Mid→Low→High)

AUTO SWING BUTTON

- Everytime you push this button, the auto swing mode is toggled.

POWER ON/OFF BUTTON

- To turn the unit ON, push this button.
To turn the unit OFF, push this button again.

MODE SELECT BUTTON

- Everytime you push this button, It is selected as follow. (COOLING→TURBO→FAN→COOLING)

Replacing Batteries

- 1** Remove the COVER from the back of the remote controller.
- Slide the cover according to the arrow direction

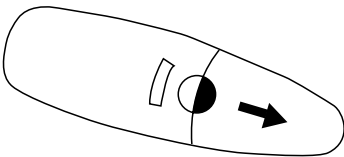

- 2** Insert two batteries.
- Be sure that the (+) and (-) directions are correct
 - Be sure that both batteries are new

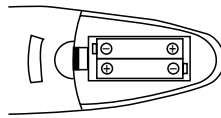

- 3** Re-attach the cover.
- Slide it back into position

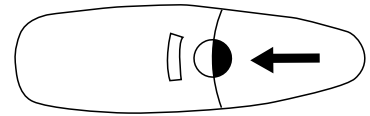

- Do not use rechargeable batteries such batteries differ from standard dry cells in shape, dimensions and performance.
- Remove the batteries from the remote controller if the air conditioner is not going to be used for an extended length of time.

4 DESCRIPTION OF FUNCTIONS

OFF-Timer

If you set time in OFF-Timer Mode, the unit will stop at the set time.

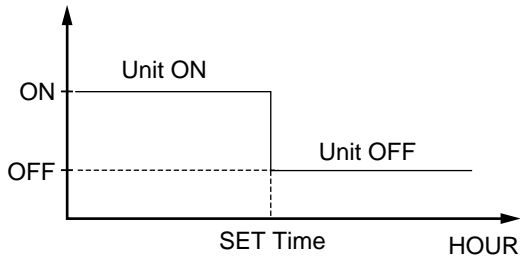

ON-Timer

If you set time in ON-Timer Mode, the unit will run at the set time.

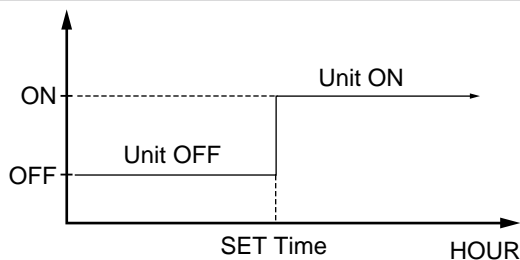

Control of Room Temperature

- (1) Range of setting temperature: 16~32°C
- (2) Setting temperature: Operating temperature of compressor

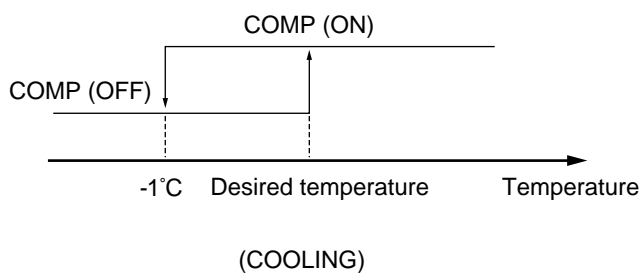

- * (Room temperature < setting temperature
Compressor OFF
- (Room temperature > setting temperature
Compressor ON

Buzzer

If the Unit Display receive the signal of Remote Controller, you can hear the signal "beep –" or "beep, beep".

Fan Speed

- (1) Motor speed (high speed, normal speed, low speed).
- (2) Remote controller setting fan speed. (H, M, L)
- (3) Relation of operating mode between fan speed.

| | FAN ONLY | COOL | TURBO |
|---|----------|------|-------|
| H | H | H | H |
| M | M | M | - |
| L | L | L | - |

Sleep Mode

- (1) When you are going to sleep, select sleep button in remote and the unit controls the room to the desired temperature. (The unit will not operate after 4 hour)
- (2) For changing the temperature.

• Mode I (L1)

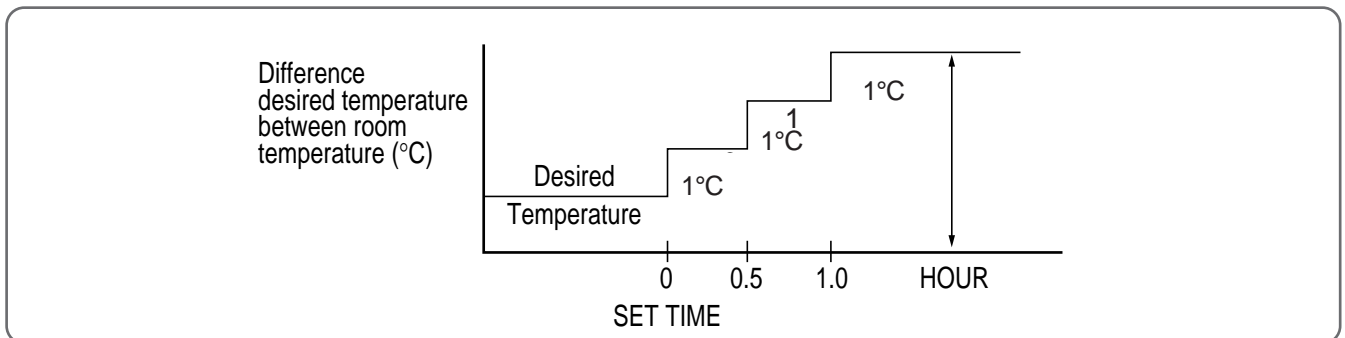

- The unit will not operate after 4 hour.

• Mode II (L2)

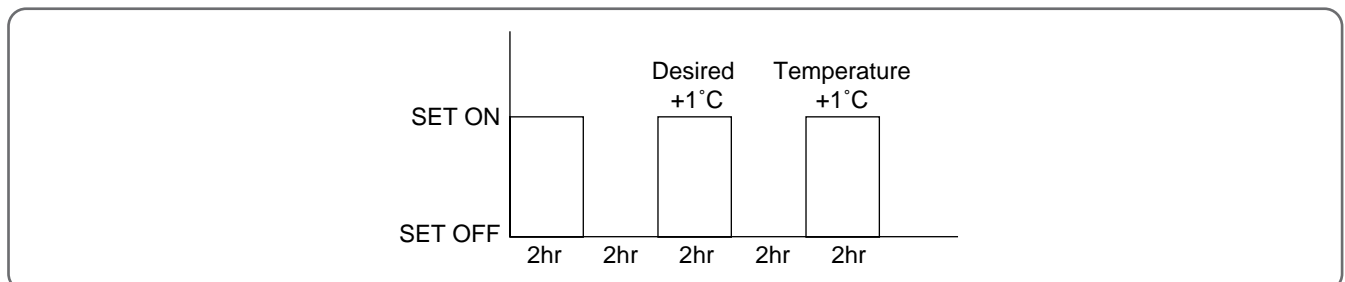

- The unit will not operate perfectly after 10 hour.

- (3) To cancel sleep mode, press the SLEEP button again or press the MODE button once. : the SLEEP indicator will disappear in the display.

3min. Time Delay of Compressor

In normal operation, there is a time delay of three minutes between turn off and turning back on including initial power up.

Auto Swing

- (1) When you push this button, in remote the left/right flap move to the position of keeping the room temperature comfortable.
- (2) The air discharge direction procedure is below.

Auto swing ←————→ Fixed

Turbo Mode(Powerful Cooling)

(1) Cooling Condition

- ① Fan Speed: High speed
- ② Set temperature: 16°C(Fixed)
- ③ Compressor and Fan

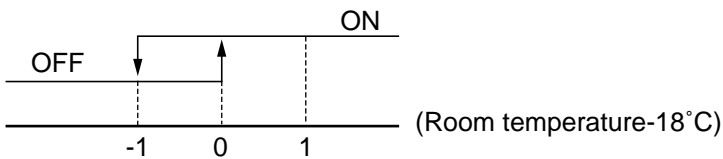

Self-Diagnostic Function

The control will contain diagnostic test to verify the integrity of the system.

(1) Error Code Display

| ERROR CODE | 88 LED DISPLAY | ERROR CONTENTS |
|------------|----------------|------------------------------------|
| 1 | | Room air thermistor short or open. |

3. WIRING DIAGRAM

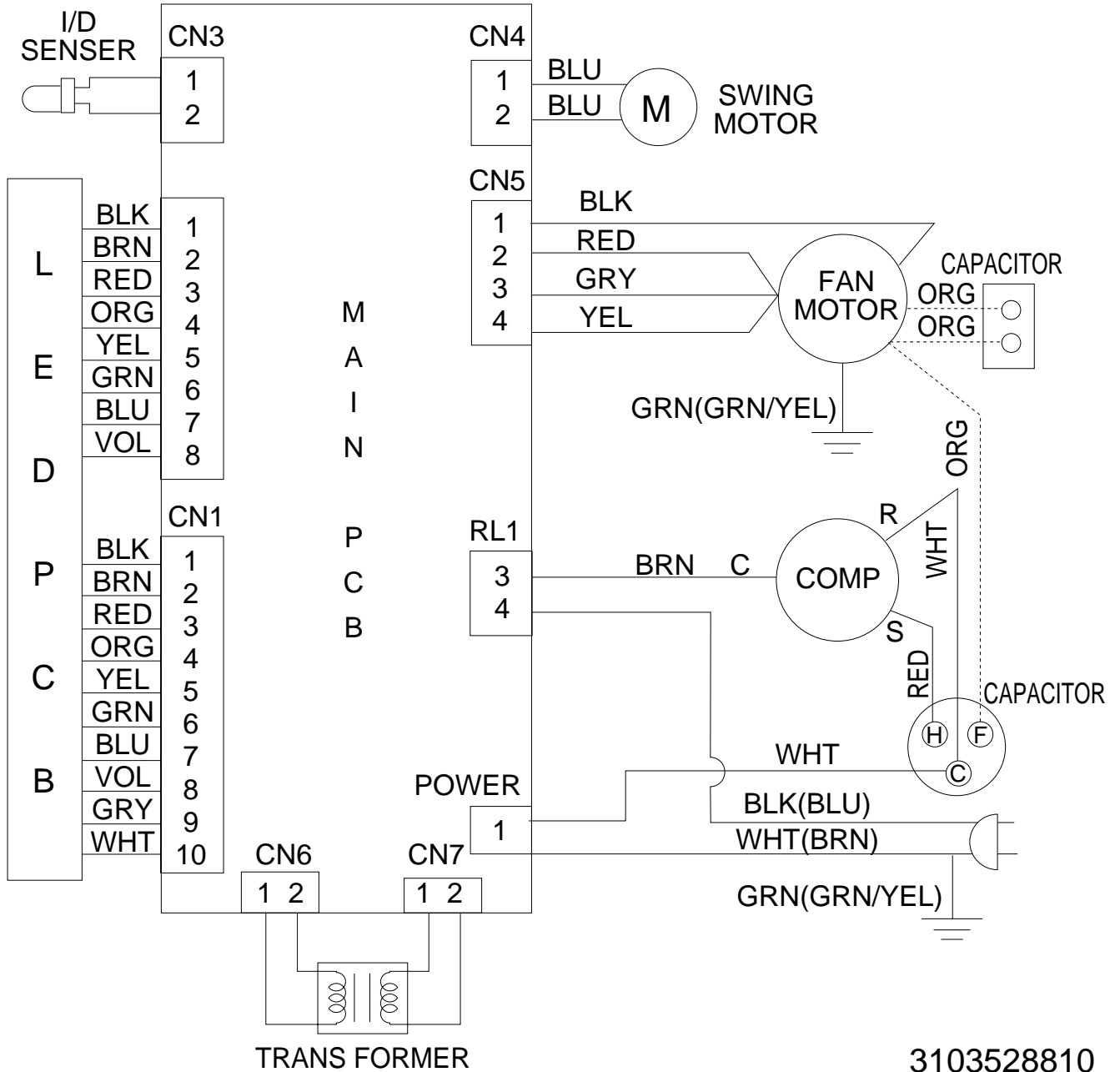

4. REFRIGERANT CYCLE

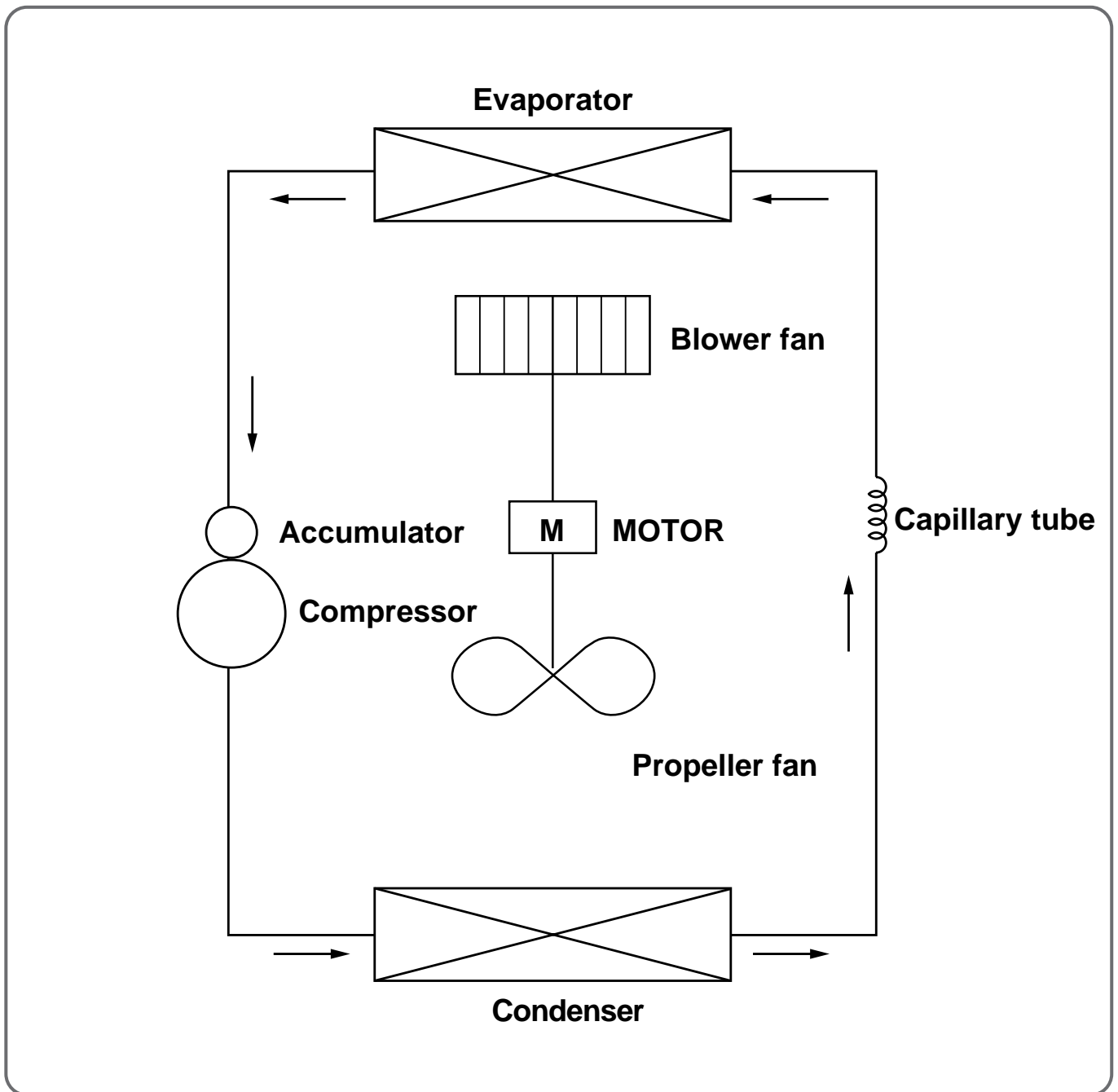

5. CONTROL BLOCK DIAGRAM

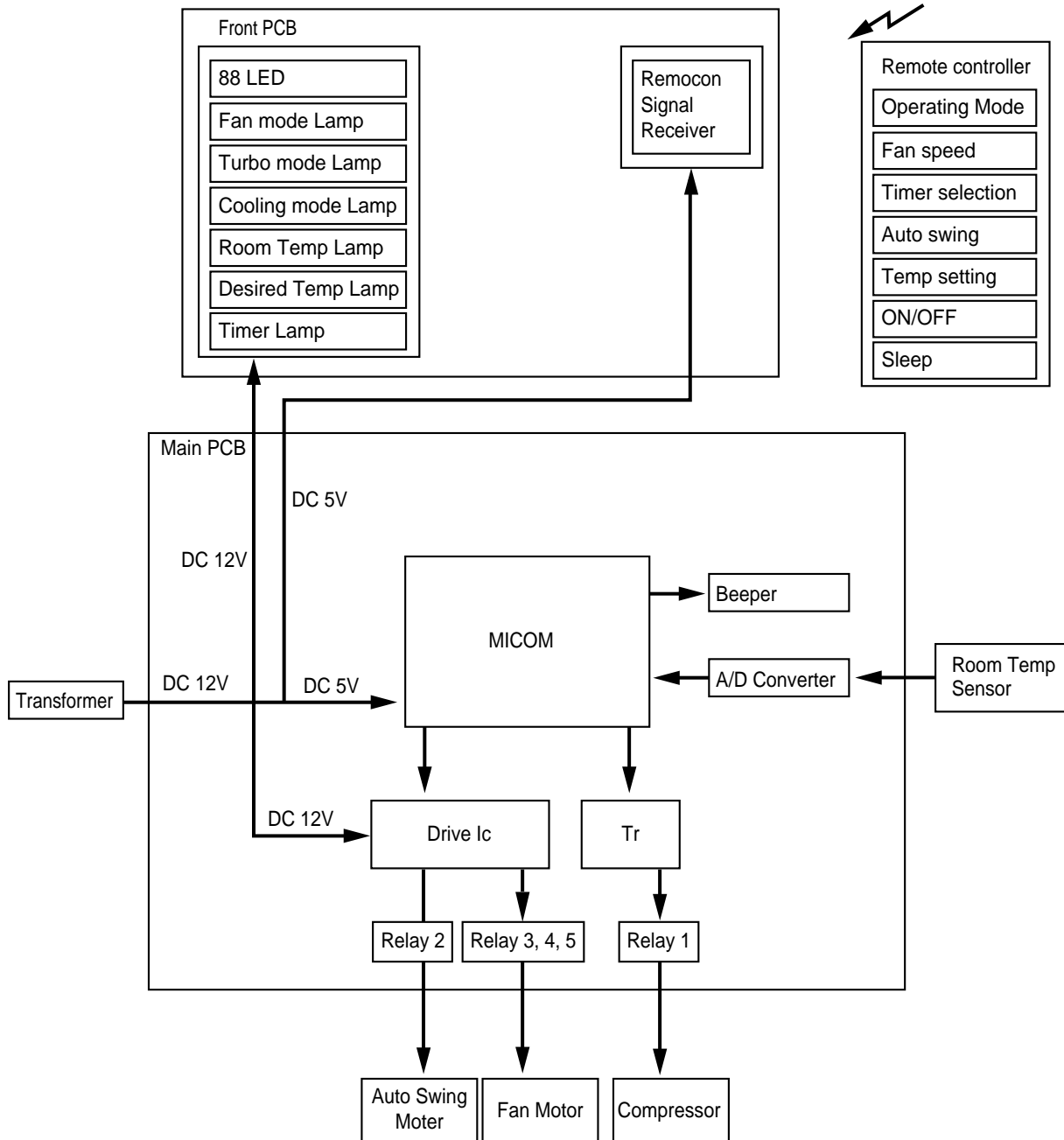

Part List

● MAIN PCB ASS'Y(3104302500)

| NO | PART NAME | SPEC | PART CODE | Q'TY | REMARK |
|----|---------------|-----------------|-------------|------|------------------------|
| 1 | IC MICOM | TMP47P443N | 13GSHK64-- | 1 | U1 |
| 2 | IC DRIVE | TD62004AP | 13GT62004A | 1 | U3 |
| 3 | IC DRIVE | TD62783AP | 13GT62783A | 1 | U2 |
| 4 | IC REGULATOR | KIA7812P | 1KA7812AP- | 1 | U4 |
| 5 | IC REGULATOR | KIA7805P | 1KA7805AP- | 1 | U5 |
| 6 | IC RESET | KIA7042P | 1KA7042P-- | 1 | U6 |
| 7 | FUSE CLIP | AFC-520 | 3107000600 | 2 | FUSE |
| 8 | FUSE | 125V, 5A | 5FULB502L- | 1 | |
| 9 | RELAY | CS11-12SH | 5SC0101128 | 4 | RL2 |
| 10 | RELAY POWER | G4A-1A | 5SC010141A | 1 | RL1 |
| 11 | RESONATOR | CST8.00MTW | 4850L03610 | 1 | OSC1 |
| 12 | VARISTOR | 15G561K | D15G561K-- | 1 | VAR1 |
| 13 | DIODE | 1N4004 | DZN4004A-- | 4 | D1-4 |
| 14 | DIODE | 1N4148 | DZN4148A-- | 1 | D5 |
| 15 | HEAT SINK | 22(H)X23X17 | 3105797200 | 1 | |
| 16 | PCB | ·ø , FR-1 | 3104302100 | 1 | |
| 17 | BUZZER | BM-20K | 3105698100 | 1 | BZ |
| 18 | TR | KRC3198Y | TZTC3198Y- | 1 | Q1 |
| 19 | WAFER | YW396-03AV | 3108802500 | 1 | CN4 |
| 20 | WAFER | YPW500-04 | 3108805500 | 1 | CN5 |
| 21 | WAFER | YW396-03AV(BK) | 3108802700 | 1 | CN6 |
| 22 | WAFER | YW500-02V | 3108803000 | 1 | CN7 |
| 23 | WAFER | SMW250-02 | 3108804200 | 1 | CN3 |
| 24 | WAFER | SMW250-08 | 3108804000 | 1 | CN2 |
| 25 | WAFER | SMW250-10 | 3108802100 | 1 | CN1 |
| 26 | WAFER | YF254S-02 | 3108804300 | 1 | TEST |
| 27 | PIN | GP881206-2 | 3108803500 | 2 | POWER |
| 28 | RESISTOR | 300, 1/4W, 5% | RD-4K301J- | 1 | R4 |
| 29 | RESISTOR | 1K, 1/4W, 5% | RD-4K102J- | 1 | R7 |
| 30 | RESISTOR | 5.6K, 1/4W, 5% | RD-4K562J- | 1 | R1 |
| 31 | RESISTOR | 10K, 1/4W, 5% | RD-4K103J- | 5 | R2,3,6,15,16 |
| 32 | RESISTOR | 12.7K, 1/4W, 5% | RD-4K1272F | 1 | R5 |
| 33 | RESISTOR | 300, 1/2W, 5% | RD-2K301J- | 7 | R8-14 |
| 34 | RESISTOR ARRY | 9A 103J | RA8K8103J- | 1 | RA1 |
| 35 | RESISTOR ARRY | 8A 102J | RA8K7102J- | 1 | RA2 |
| 36 | C-ELEC | 1000μF 35V SD | CEXE1V108C | 1 | C2 |
| 37 | C-ELEC | 470μF 25V SD | CEXE1E477C | 1 | C5 |
| 38 | C-ELEC | 100μF 16V SD | CEXE1C107C | 1 | C7 |
| 39 | C-ELEC | 10μF 50V SD | CEXE1C106C | 1 | C10 |
| 40 | C-ELEC | 4.7μF 50V SD | CEXE1H475C | 1 | C11 |
| 41 | C-CERA | 103Z 50VDC | CCXE1H103M | 1 | C13 |
| 42 | C-CERA | 104Z 25VDC | CCXE1EH104M | 7 | C2-4,6, 9,12,13 |
| 43 | JUMPER | 10MM | 3109400100 | 14 | J1-6,9,12 J14-16,18 |
| 44 | JUMPER | 6MM | 3109400200 | 4 | J7-8,13,17 |

●Front PCB ASS'Y(3104302400)

| NO | PART NAME | SPEC | PART CODE | Q'TY | REMARK |
|----|----------------|--------------|------------|------|--------|
| 1 | LED DISPLAY | 88 | 3103003700 | 1 | DISP |
| 2 | C-CERA | 103Z 50VDC | CXCH1H103M | 1 | C1 |
| 3 | RECEIVE MODULE | PIC-26043TH2 | 1PC26043TH | 1 | REMO |
| 4 | LED | DLSO-5031D | DDLS05031D | 3 | |
| 5 | LED | DLG-5031D | DDLG5031D- | 3 | |
| 6 | SWITCH TACT | JTP1212 | 3109300900 | 6 | |
| 7 | DIODE | 1N4148 | DZN4148A-- | 6 | D1-6 |
| 8 | WAFER | SMAW250-08 | 3108804800 | 1 | CN1 |
| 9 | WAFER | SMAW250-10 | 3108802400 | 1 | CN2 |
| 10 | PCB | ·ø , FR-1 | 3104302200 | 1 | |
| 11 | JUMPER | 10mm | 3109400100 | 7 | J1-7 |

●Remocon ASS'Y(3108402900)

| NO | PART NAME | SPEC | PART CODE | Q'TY | REMARK |
|----|-------------------|-----------------|------------|------|--------|
| 1 | CASE-A | ABS380 | 3101100510 | 1 | |
| 2 | CASE-B | BAS380 | 3101100600 | 1 | |
| 3 | CUSHION KEY | SILICON 6U | 3101405900 | 1 | |
| 4 | SPRING A | SUS304 | 3105100600 | 1 | |
| 5 | SPRING B | SUS304 | 3105100700 | 1 | |
| 6 | COMMON SPRING | SUS304 | 3105100800 | 1 | |
| 7 | SCREW A | M1.9*6.5 | 3108495110 | 3 | |
| 8 | RESONATOR | RJ-455BL | 5ZAR455--- | 1 | X1 |
| 9 | ELEC CONDENSOR | 10VB 47M | CEAF10475M | 1 | C1 |
| 10 | CHIP CONDENSOR | CETMK212F221Z-T | HCQD220MQ | 2 | C2,3 |
| 11 | CHIP RESISTOR | 1/10W 1.5 OHM | HRFT159JCP | 1 | R1 |
| 12 | CHIP RESISTOR | 1/10W100K OHM | HRFT104JCP | 3 | R2,3,4 |
| 13 | TRANSISTOR | STN2222 | TSTN2222- | 1 | Q1 |
| 14 | LED IR | SI5312-H | DS5312-H-- | 1 | IR1 |
| 15 | IC REMOCON | PT2221 | 14EZPT2221 | 1 | U1 |
| 16 | COVER BTRY | ABS | 3101405900 | 1 | |
| 17 | PCB REMOCON | FR-1 | 3104302000 | 1 | |
| 18 | HOLDER REMOCON | ABS | 3103003400 | 1 | |

7. TROUBLE SHOOTING

Self-Diagnostic Function

1) Error Code 1(Er)

- ① Check the connector of room air thermistor. (or connecting wire)
- ② Check soldering of connecting on control P.C.B. (Error of soldering or short)
- ③ Check the resistance of room air thermistor.

“Press the temperature Keys (Up & Down), Error code is displayed.”

Unit Not Run

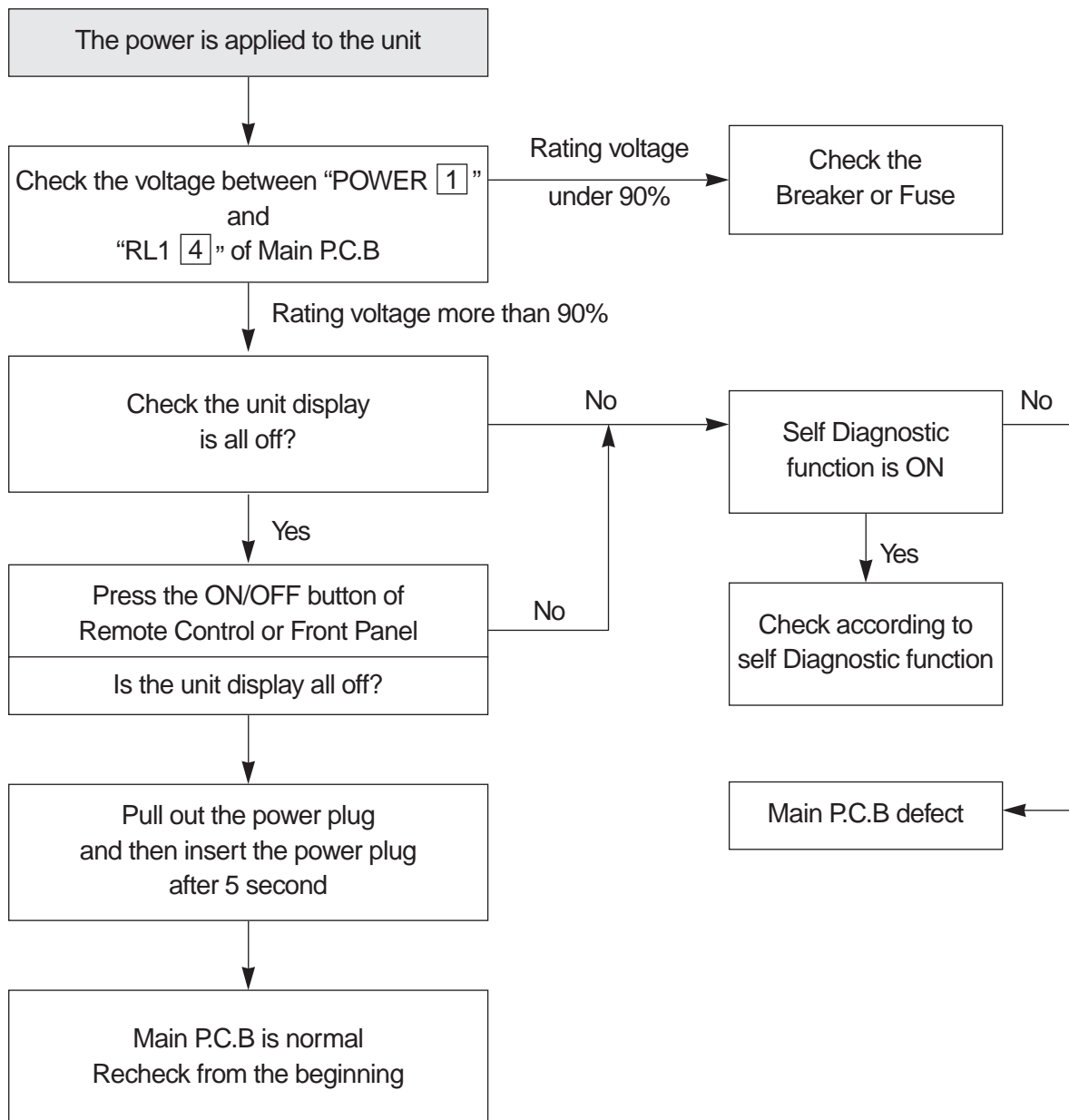

Only Compressor Do not Run

- Check the following at cooling mode

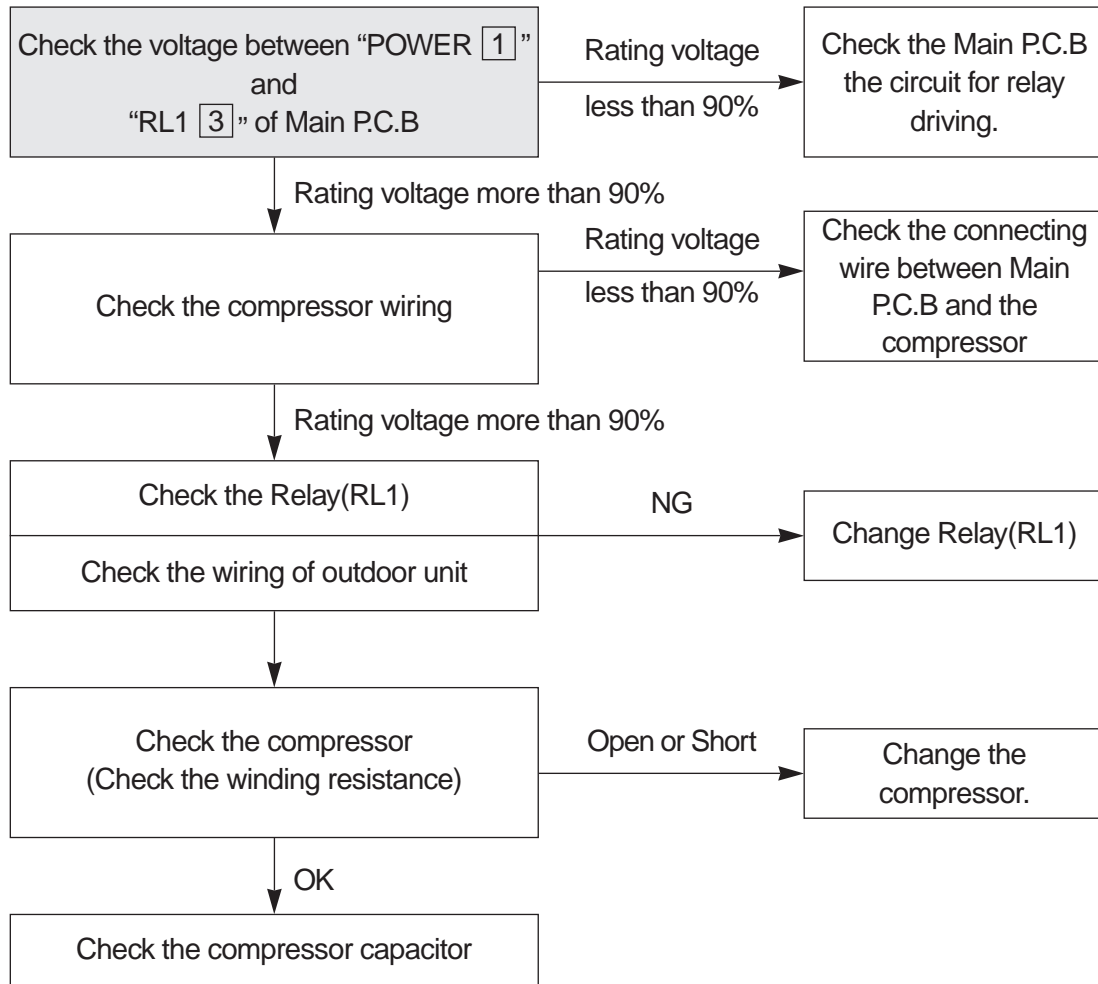

PCB DRIVING DESCRIPTION

Power Supply(1)

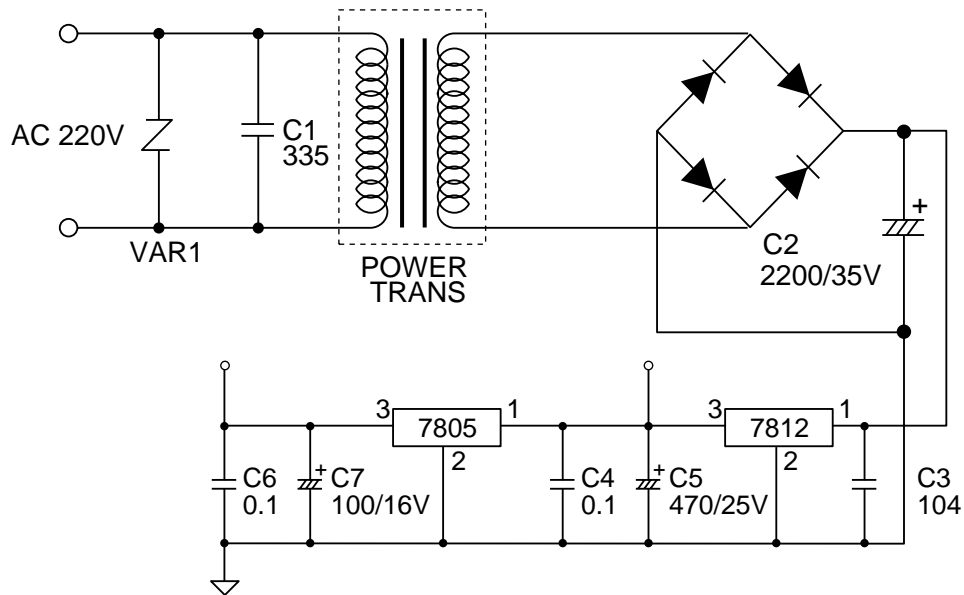

DESCRIPTION

DC Power Supply in circuit needs +12V and +5V. +12V is used for Compressor Driving Relay, Fan Motor Driving Relay, Buzzer Driving, Swing Motor Driving Relay and LED Display. AC voltage of secondary Power Transformer is rectified by 4 Diode, and it is filtering by Main Condensor C2.

Filtered DC voltage is about +17V is regulated +12V DC by Regulator IC7812.

And it is regulated +5V DC by Regulator IC7805.

VAR1 is surge filter and C4, C6 is Noise filter.

Oscillation(2)

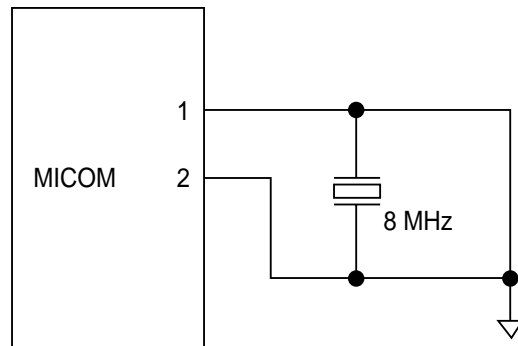

DESCRIPTION

Oscillatory Frequency drive Micom, it is made up 8MHz resonator oscillatory Frequency.
Oscillatory wave is as following Fig 2-1.

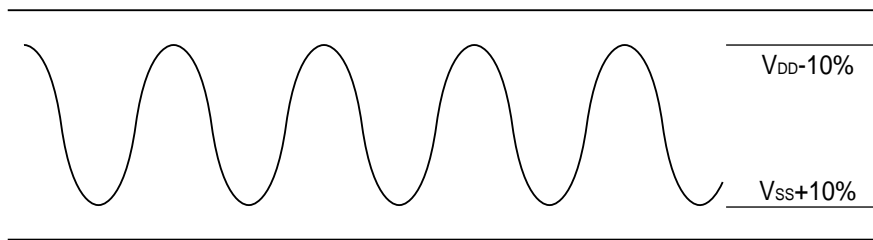
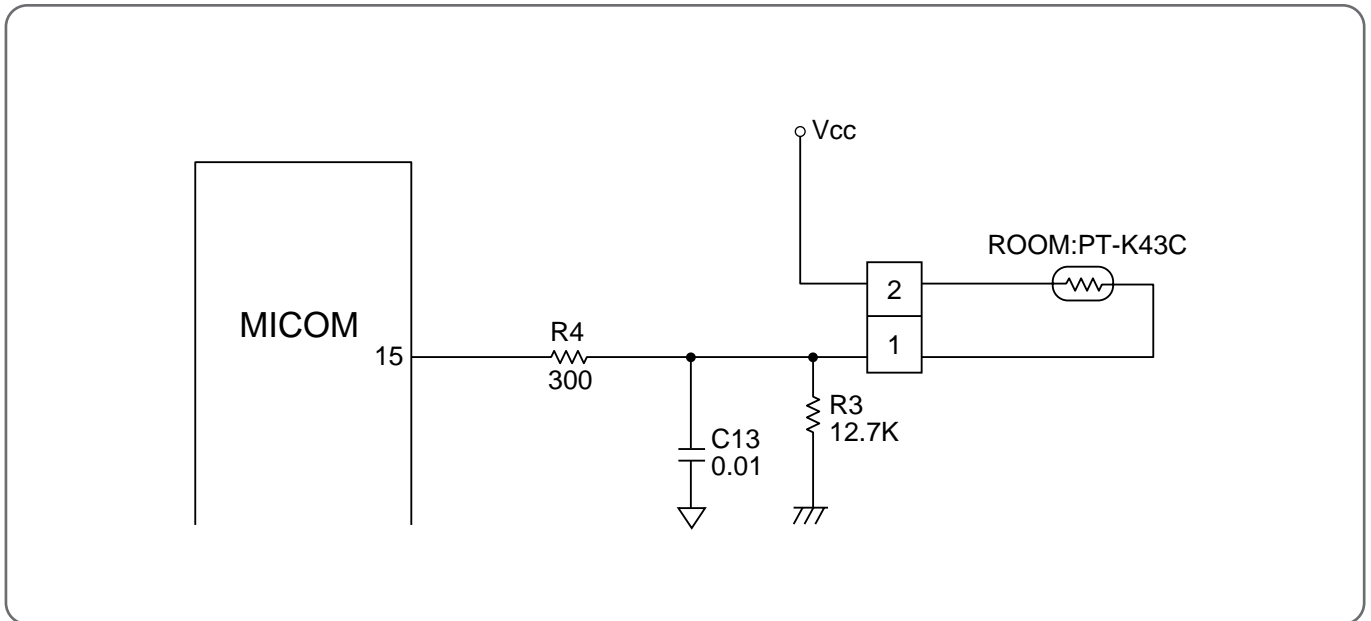

Fig 2-1

Sensor(3)

Room temperature Sensor Input



DESCRIPTION

Number 15 of Micom is Terminal of A/D convertor Input.

Room temperature is sensing by change of Thermister Resistance, Micom is put in 5V by ratio between R3 (12.7K Ω) and Room sensor.

Relation between temperature and voltage is following Table 3-1.

C13 is Noise filter.

| Temperature (°C) | Voltage (V) |
|------------------|-------------|
| | No. 15 |
| -10 | 4.06 |
| 0 | 3.60 |
| 15 | 2.76 |
| 25 | 2.20 |
| 40 | 1.48 |

Table 3-1

Remote Controller(4)

DESCRIPTION

Signal from Remote Controller put in only Control Data Signal at Micom Terminal of Number 5, which is gotten field of Carrier (38KHz) from Receive Module. Signal Wave repeat third as following Fig 5-1. But in Secondary Wave Custom Code is Reversed Face.

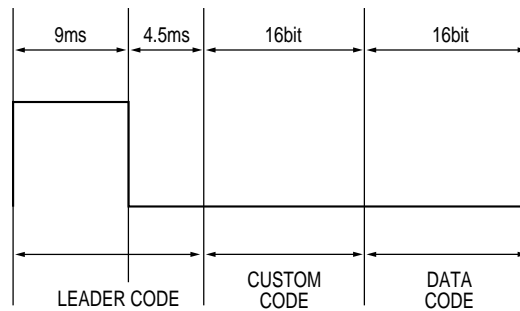

Fig 5-1

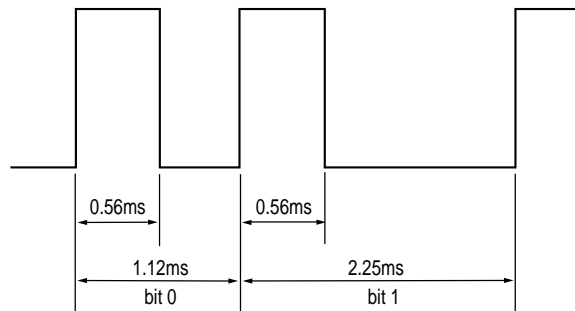
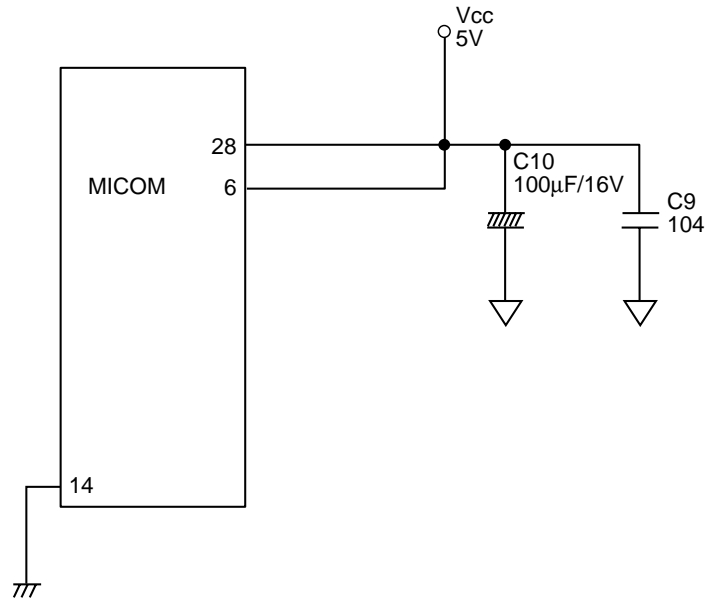

Fig 5-2
BIT STRUCTURE

Micom Power Supply(5)



DESCRIPTION

MICOM Power is supplied 5V at Number 28 using VDD, Number 6 using Analog Reference of A/D Converter. C9, C10 is Ripple filter.

Reset(6)

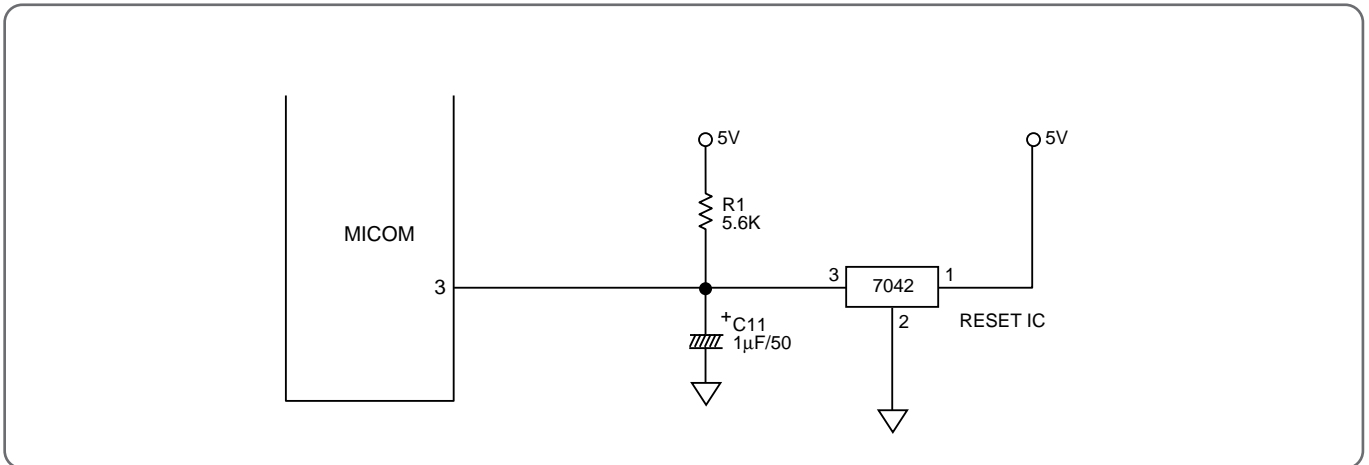

DESCRIPTION

Voltage less than about 4.2V put in Micom Terminal of Number 6 and then Micom reset. Reset IC detect Power ON and Voltage greater than 4.2V, and then send Reset Signal.

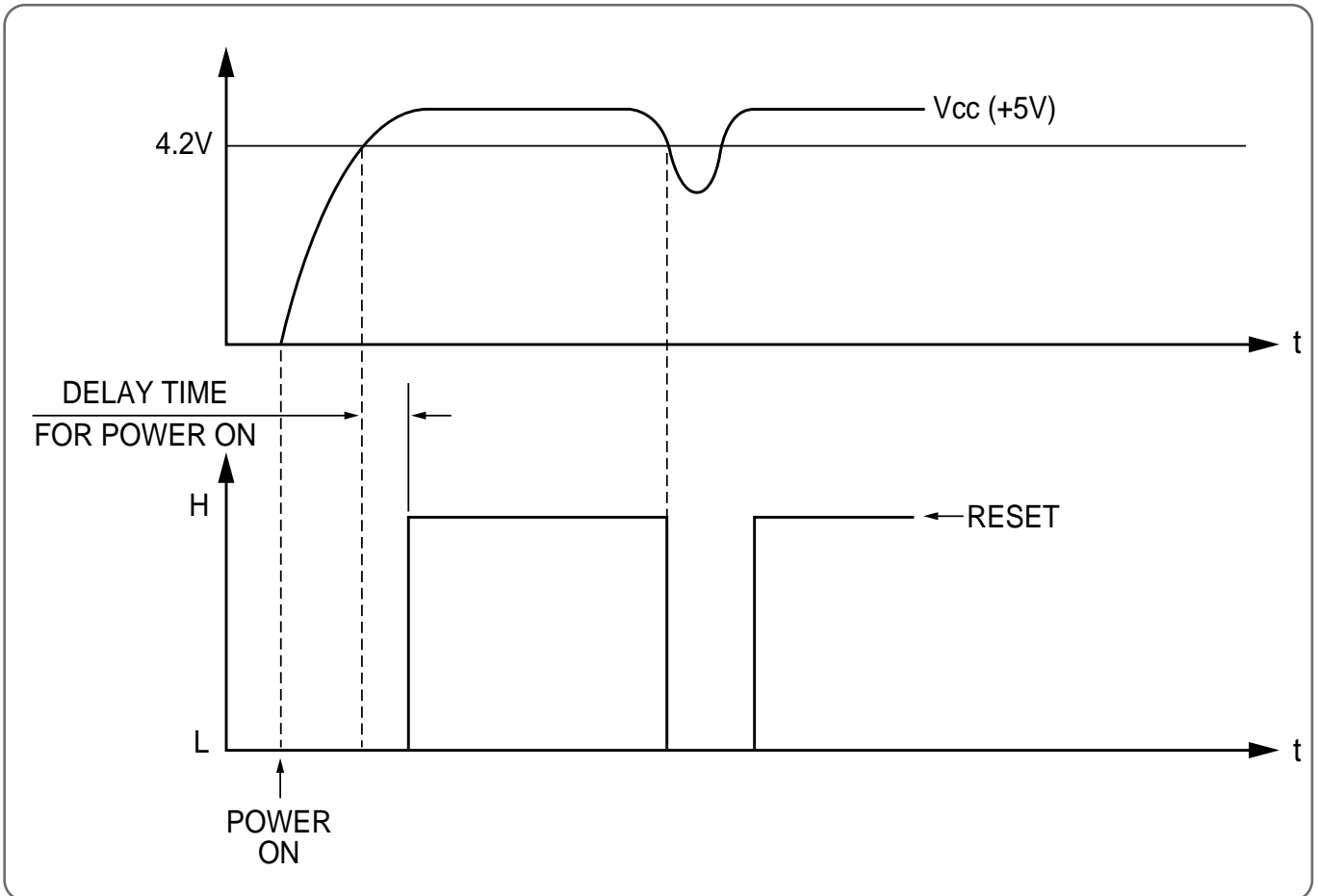

Function Selecting(7)

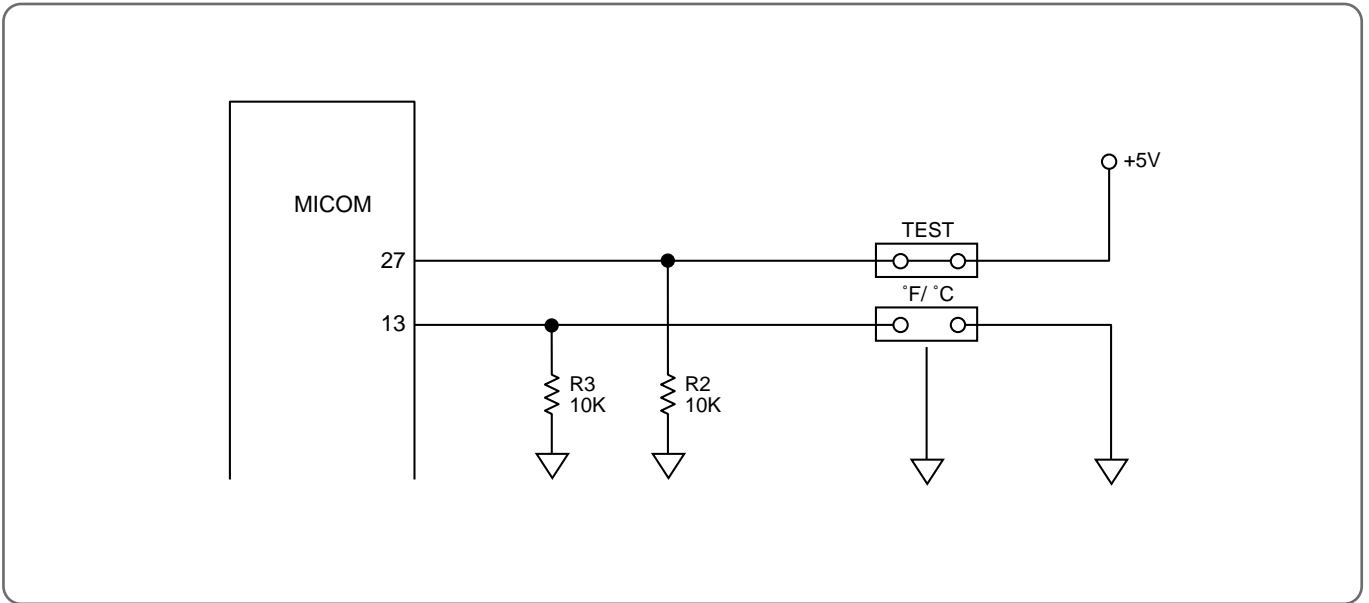

DESCRIPTION

Selecting Function is as following table 9-1.

| Selection S/W | SHORT | OPEN |
|---------------|-------|------|
| Function | | |
| °F / °C | °F | °C |
| TEST | OK | NO |

Table 9-1

8. KEY COMPONENTS OF ELECTRONIC CIRCUIT

(1) IC3 (MICOM)

TMP47C443N

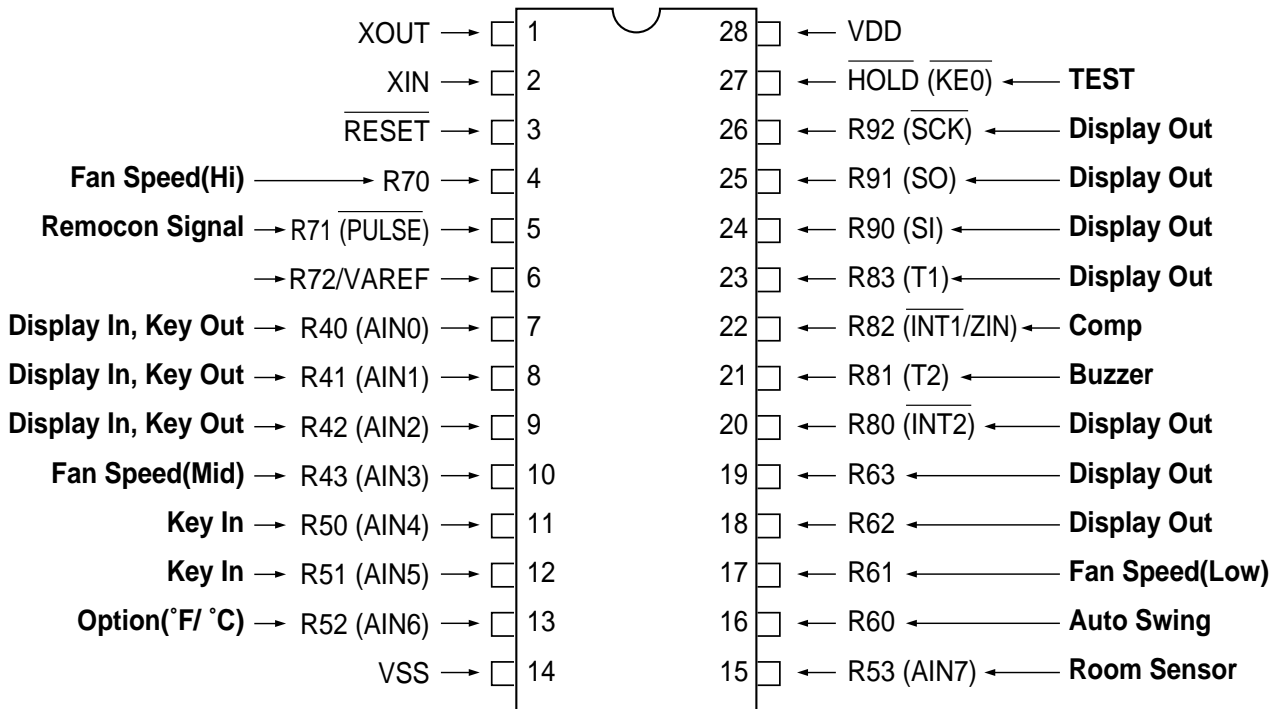

(2) U2 (TD62783AP)

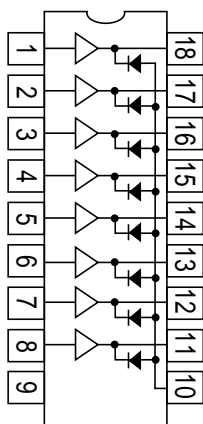

(Top View)

SCHEMATIC DIAGRAM

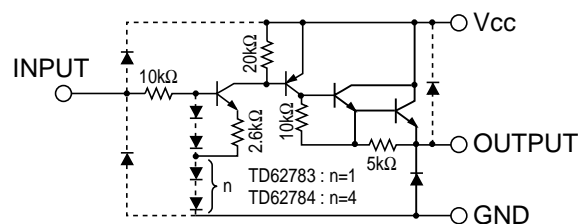

9. DISASSEMBLY INSTRUCTIONS

Please refer to the chapter 10 (Exploded diagram and parts list).

| | | |
|---|--|---|
| 1 | Before service of any part. | <ol style="list-style-type: none"> 1. Stop the unit, remove the power cord from the receptacles. 2. Move the unit to the safe location for the suitable work. |
| 2 | Ass'y Fan Motor - Fan Motor - Propeller Fan - Blower Fan | <ol style="list-style-type: none"> 1. Remove Front Grille. <ul style="list-style-type: none"> - Remove Filter Pre. - Remove screw(2 point) in Front Grille. 2. Remove Cabinet from the unit. <ul style="list-style-type: none"> - Remove screws (2 point) from the unit's sides. 3. Remove Holder Scroll. 4. Remove Scroll upper 5. Remove Ass'y Control Box <ul style="list-style-type: none"> - Remove screws (4 point). - Remove wires in the each components. 6. Remove wires in the Panel Housing. 7. Remove screws (4 point) from Ass'y Fan Motor's sides. <ul style="list-style-type: none"> - Ass'y Fan Motor is assembly of Fan Motor, Propeller and Blower Fan, Orifice and Panel Housing. 8. Lift the Ass'y Fan Motor from the unit. 9. Remove Clip Fan (2 point) from the shaft of Fan Motor. 10. Remove Propeller Fan from the shaft of Fan Motor. 11. Remove Blower Fan from the shaft of Fan Motor. 12. Remove Fan Motor from Panel Housing. <ul style="list-style-type: none"> - Remove screws (4 point). |
| 3 | Ass'y Control Box - Panel Control - Main Pcb - Front Pcb - Capacitor - Power Cord | <ol style="list-style-type: none"> 1. Same as the procedure 1 to 5 in the Item 2. |
| 4 | O.L.P | <ol style="list-style-type: none"> 1. Same as the procedure 1 to 2 in the Item 2. 2. Remove Terminal Cover from Compressor. <ul style="list-style-type: none"> - Remove hex-nut (1 point). |

10. EXPLODED DIAGRAM AND PARTS LIST

■ DWA-180R PARTS LIST

| No. | CODE | COMPONENTS | Q'TY | SPECIFICATION | REMARK |
|-----|------------|------------------------|------|--------------------------|---------------------|
| 1 | 3100066210 | ASS'Y PAN BASE | 1 | ASS'Y | |
| 2 | | COMP BOLT | 3 | M8 | COMP ACCESSORY PART |
| 3 | 3100002900 | ASS'Y SEAL CAP DRAIN | 1 | ASS'Y | |
| 4 | 3106600901 | SCROLL LOWER | 1 | EPS | |
| 5 | 3106700400 | CAM | 1 | POM | |
| 6 | 3104600110 | RING VENT | 1 | NBR P6 | |
| 7 | 3101700300 | LEVER VENT | 1 | PP (H-540) | |
| 8 | 3100066500 | AS EVA | 1 | 3R-2C(P1.4) | |
| 9 | 3104427300 | PIPE EVA IN (1) | 1 | C1220T-0D 9.52 | |
| 10 | 3104427310 | PIPE EVA IN (2) | 1 | C1220T-0D 9.52 | |
| 11 | 3100068450 | ASS'Y PIPE EVA OUT (A) | 1 | C1220T-0D 9.52 | |
| 12 | 3100068440 | ASS'Y PIPE EVA IN (B) | 1 | C1220T-0D 9.52 | |
| 13 | 3106600801 | SCROLL UPPER | 1 | EPS | |
| 14 | 3107101500 | COMPRESSOR | 1 | QJ250KD24A(LG) | |
| 15 | | WASHER PLAIN | 3 | M8 | COMP ACCESSORY PART |
| 16 | | NUT LOCK | 3 | M8 | COMP ACCESSORY PART |
| 17 | | GROMMET | 3 | | COMP ACCESSORY PART |
| 18 | | GASKET | 1 | SILICON | COMP ACCESSORY PART |
| 19 | | COVER TERMINAL | 1 | PP | COMP ACCESSORY PART |
| 20 | 3102708010 | HARNESS COMP ASS'Y | 1 | AWG-14x3(UL) | |
| 21 | 3107000500 | FAN CLIP | 2 | SK5 | |
| 22 | 3101802800 | FAN BLOWER | 1 | ABS(ABS-730) | |
| 23 | 3104202301 | PANEL HOUSING | 1 | SGCC T1.0 | |
| 24 | 3108506500 | SEAL HOUSING | 1 | F-PE + US | |
| 25 | 3100701600 | BUSHING P.H | 1 | MASS | |
| 26 | 3104409400 | RUBBER PIPE BUTTYL 2 | 4 | MASS | |
| 27 | 3108005630 | MOTOR FAN | 1 | SUNGSHIN (IC-1260DWWF6B) | |
| 28 | 3100701500 | BUSHING GUIDE | 1 | NBR | |
| 29 | 7S432X5121 | SPECIAL SCREW | 4 | TT3/HEX 5x12 | |
| 30 | 3101405401 | COVER ORIFICE | 1 | PP (M540) | |
| 31 | 3100066700 | LOCK WIRE STANDOFF | 2 | | |
| 32 | 3101802900 | FAN PROPELLER | 1 | ABS+GF20% | |
| 33 | 3100058200 | AS CABINET WL | 1 | ASSY | |
| 34 | 3108505300 | SEAL CABINET TOP | 1 | F-PE+US | |
| 35 | 3108505400 | SEAL CABINET SIDE(L) | 1 | F-US | |
| 36 | 3108505500 | SEAL CABINET SIDE(R) | 1 | F-US | |
| 37 | 3108505600 | SEAL COND TOP | 1 | F-US | |
| 38 | 3100066300 | ASS'Y CONDENSOR | 1 | 2R-1C(P1.4) | |

| No. | CODE | COMPONENTS | Q'TY | SPECIFICATION | REMARK |
|-----|------------|----------------------|------|----------------------|--------|
| 39 | 3100068400 | AS PIPE COND IN (A) | 1 | C1220T-0D 7.94 | |
| 40 | 3100068420 | AS PIPE COND OUT (A) | 1 | C1220T-0D 9.52 | |
| 41 | 3104429600 | AS PIPE COND IN (C) | 1 | C1220T-0D 7.94 | |
| 42 | 3100071800 | AS PIPE DISCHARGE | 1 | ASSY | |
| 43 | 3100071900 | AS PIPE SUNCTION | 1 | ASSY | |
| 44 | 3100067900 | ASS'Y GRILLE FRONT | 1 | ASSY | |
| 45 | 3108505200 | SEAL GRILLE FRONT | | F-US | |
| 46 | 3106502201 | BLADE VERTICAL | 1 | HIPS | |
| 47 | 3106502100 | BLADE HORIZONTAL | 2 | PP | |
| 48 | 3101902201 | FILTER PRE | 1 | HIPS+MESH | |
| 49 | 7112401011 | SCREW TAPPING | 1 | T1 TRS 4x10 | |
| 50 | 3101600800 | DECO FRONT | 1 | PC T0.2 | |
| 51 | 3966031000 | MOTOR SYNCRO | 1 | MN73SHBJ | |
| 52 | 7122300611 | SCREW TAPPING | 2 | T2S PAN 3x6 | |
| 53 | 3100509210 | BOX CONTROL | 1 | SGCC T0.8 | |
| 54 | 3106902000 | CAPACITOR COMP | 1 | 30/400 VAC(SUNGSHIN) | |
| 55 | 3106901800 | CAPACITOR MOTOR | 1 | 6/400 VAC(SUNGSHIN) | |
| 56 | 3101201500 | CLAMP CAPACITOR | 1 | | |
| 57 | 7122401011 | SCREW TAPTITE | 1 | T1 TRS 4x10 | |
| 58 | 3101300420 | POWER CORD | 1 | AP-33 | |
| 59 | 3101203100 | CLAMP POWER CORD | 1 | DA-6N | |
| 60 | 7122401011 | SCREW TAPTITE | 1 | T1 TRS 4x10 | |
| 61 | 3108505800 | SEAL CONTROL BOX | 1 | F-PE | |
| 62 | 5EPU040100 | TRANSFORMER | 1 | DWA-230A | |
| 63 | 7112400811 | SCREW TAPPING | 2 | T1 TRS 4x8 | |
| 64 | 3104302500 | ASS'Y MAIN PCB | 1 | | |
| 65 | 3105000100 | SPACER LOCKING | 4 | DABS-8R | |
| 66 | 3105000110 | SPACER BOARD | 1 | DACBS-8R | |
| 67 | 3104302400 | ASS'Y FRONT PCB | 1 | | |
| 68 | 7122300611 | SCREW TAPPING | 2 | T2S PAN 3x6 | |
| 69 | 3108402900 | ASS'Y REMOCON | 1 | | |
| 70 | 3104202500 | PANEL CONTROL | 1 | HIPS | |
| 69 | 3102708510 | HARNESS DISPLAY 1 | 1 | UL 1015-18 | |
| 70 | 3102708610 | HARNESS DISPLAY 2 | 1 | UL 1015-18 | |
| 71 | 3102708900 | HARNESS COIL SENSOR | 1 | PTC-K43C-D2 | |
| 73 | 3103534830 | LABEL SPEC | 1 | | |
| 74 | 3103905420 | MANUAL OWNER'S | 1 | | |

■ DWA-180R

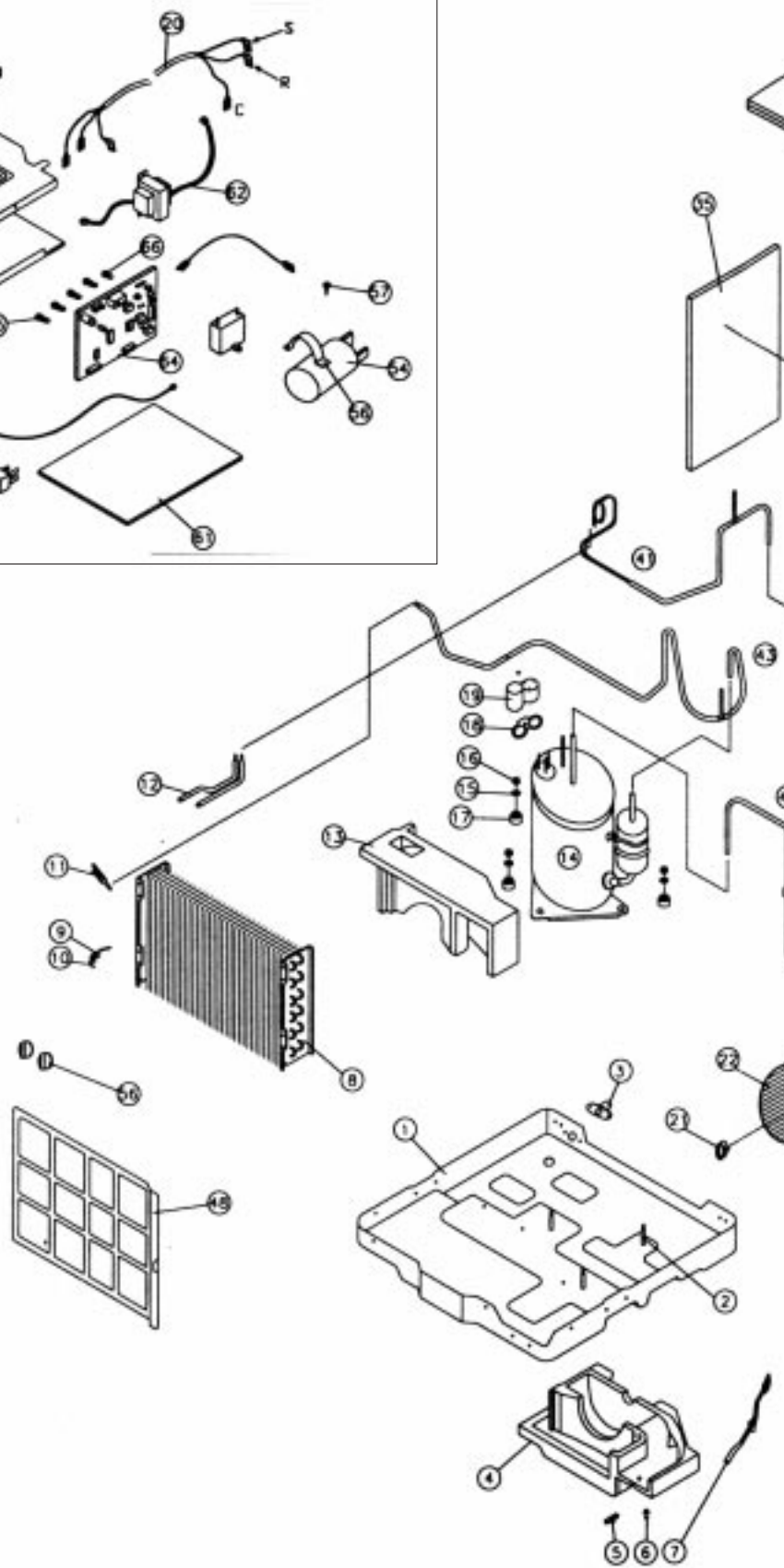
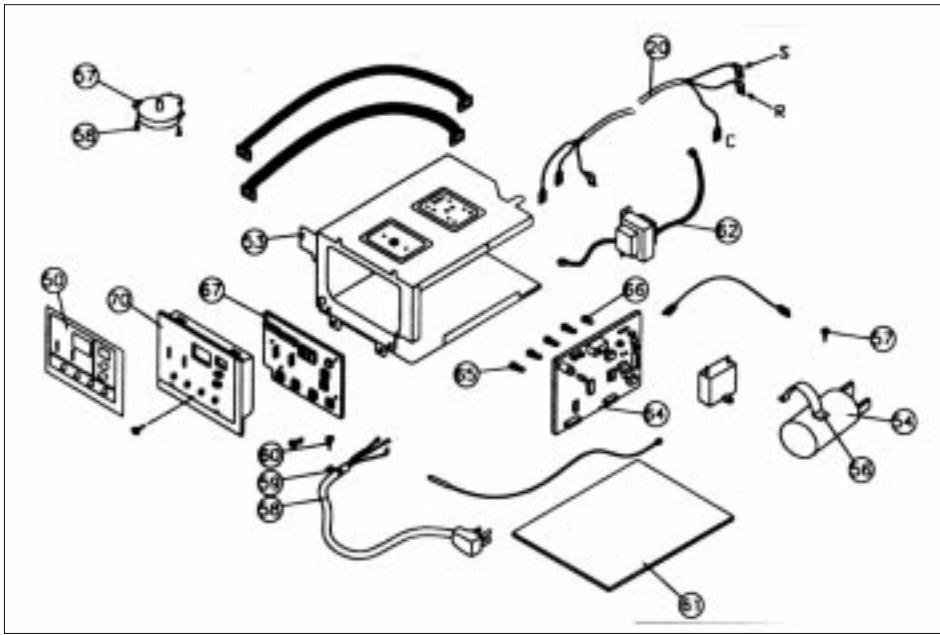

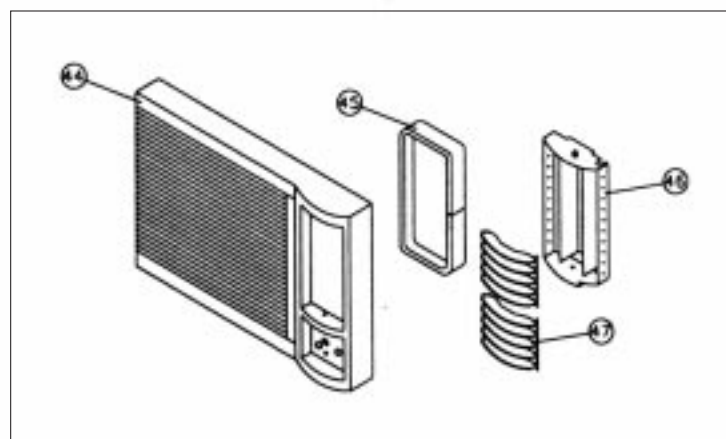
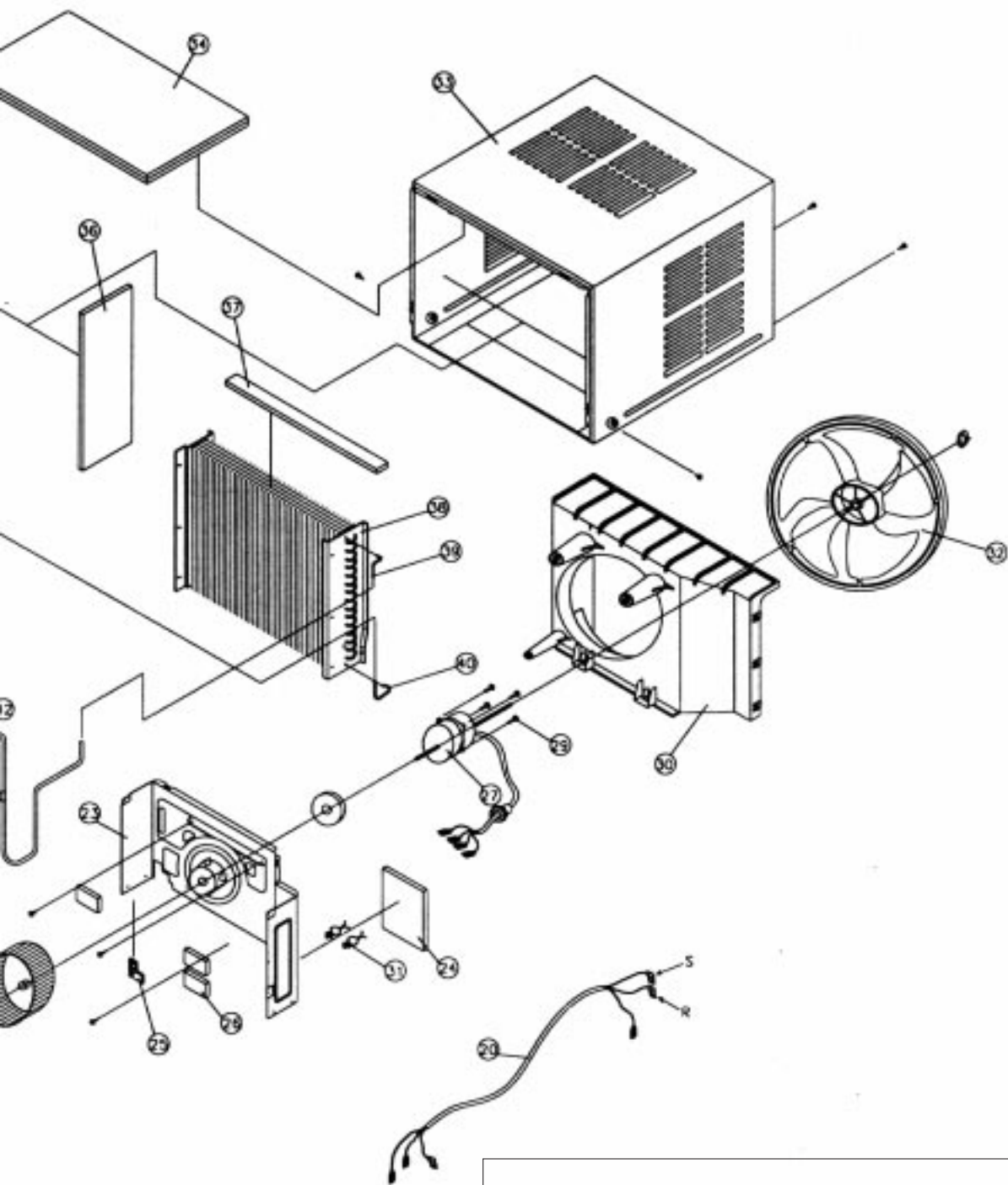

DAEWOO

DAEWOO ELECTRONICS CO., LTD.

686, AHYEON-DONG MAPO-GU SEOUL, KOREA

C.P.O. BOX 8003 SEOUL, KOREA

TELEX: DWELEC K28177-8

CABLE: "DAEWOOELEC"

FAX: 02) 590-6291

TEL: 02) 360-7114/590-6151~5

<http://www.dwe.daewoo.co.kr>

PRINTED DATE: OCT.1999

S/M NO.: DWA180R010

DAEWOO

Service Manual

**Window Type
Room Air Conditioner**

Model: DWA-180R



DAEWOO ELECTRONICS CO., LTD.